

V150-2 Schematics

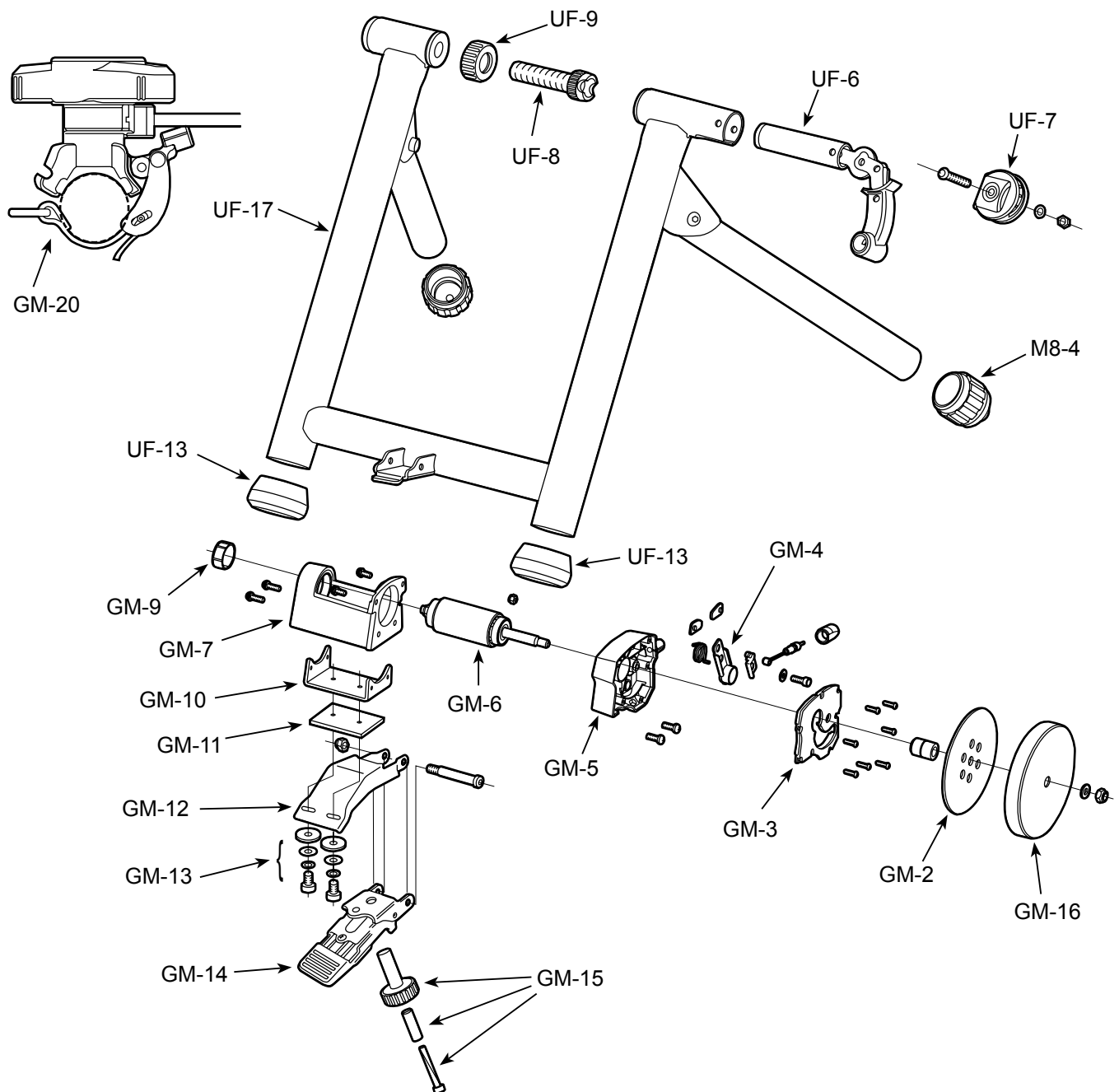

UF-6: Right Side Coupling & Clamp Lever

UF-7: Clamp Lever Guide

UF-8: Left Side Coupling

UF-9: Coupling Lock Ring (Red)

UF-13: Rubber Cap (45mm)

UF-17: V150-2 Main Frame (White)

M8-4: Rubber Foot Cap (35mm)

GM-2: Alloy Rotor

GM-3: Housing Cover

GM-4: Neodymium Magnet (for V130/150/270)

GM-5: Main Housing

GM-6: Drive Roller, Axle & Bearing

GM-7: Drive Roller Holder

GM-9: Axle End Cap

GM-10: Mag Unit Fitting Bracket

GM-11: Rubber Shim

GM-12: Mount Base

GM-13: Rubber Washer & Bolt Set

GM-14: Foot Pedal

GM-15: Micro Adjust Knob

GM-16: Flywheel (1.5 kgs for V130/150)

GM-20: Remote Shifter (Chrome Plated)