

GYRO V150 Schematics

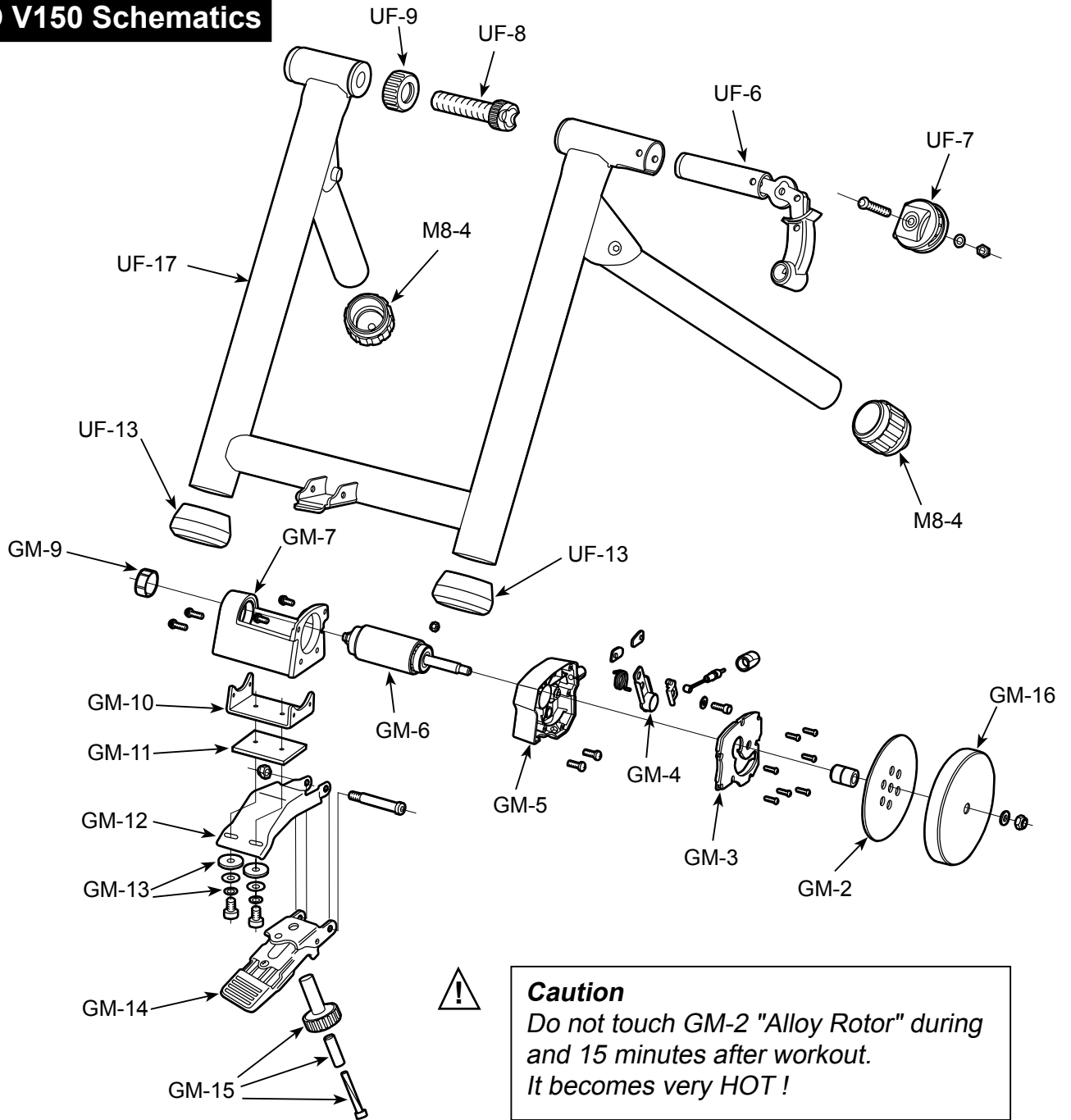

- UF-6 : Right Side Coupling & Clamp Lever
- UF-7 : Clamp Lever Guide
- UF-8 : Left Side Coupling
- UF-9 : Coupling Lock Ring
- UF-13 : Rubber Cap (45mm)
- UF-17 : V150-2 Main Frame
- M8-4 : Rubber Foot Cap (35mm)
- GM-2 : Alloy Rotor
- GM-3 : Housing Cover
- GM-4 : Neodymium Magnet
- GM-5 : Main Housing

- GM-6 : Drive Roller, Axle & Bearing
- GM-7 : Drive Roller Holder
- GM-9 : Axle End Cap
- GM-10 : Mag Unit Fitting Bracket
- GM-11 : Rubber Shim
- GM-12 : Mount Base
- GM-13 : Rubber Washer Set
- GM-14 : Foot Pedal
- GM-15 : Micro Adjust Knob
- GM-16 : V150 Flywheel