

# MINOURA V150 -2

## Indoor Bicycle Trainer – instructions manual

(ver.1.2 2010/3)

### Applicable Tire Size Capacity

- Without Z-Adaptor: 26x1.5 - 700x40c
- With Z-Adaptor: 22x1-3/8 - 26x1.25

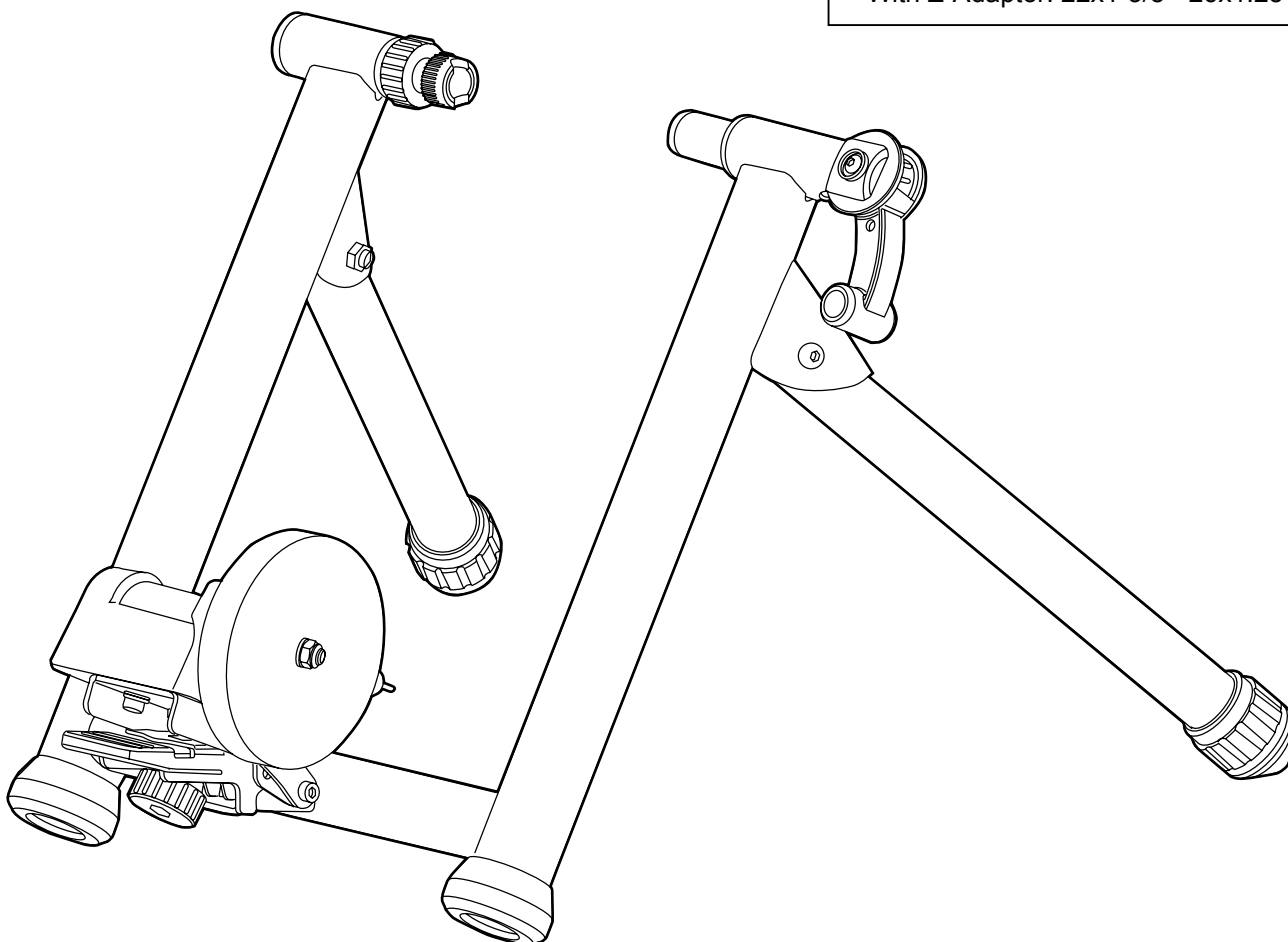

Read this instructions carefully before use

### Minoura Japan Headquarters

*(for all customers)*

1197-1 Godo, Anpachi, Gifu 503-2305 Japan

Phone: +81-584-27-3131 / Fax: +81-584-27-7505

Email: [minoura@minoura.jp](mailto:minoura@minoura.jp)

[www.minoura.jp](http://www.minoura.jp)

### Minoura North American Tech Center

*(for U.S. residents only)*

1996 East Avenue, Hayward, CA 94541 U.S.A.

Phone: 1-510-538-8599 / Fax: 1-510-538-5899

Email: [support@minourausa.com](mailto:support@minourausa.com)

**Made in Japan**

# MINOURA

## IMPORTANT NOTICE

- *For use with a normal 2-wheel bicycle only. Do not use a tandem, recumbent, or other.*
- *Hub nut type rear wheel axle is not compatible with V150 in standard. You need to replace the left side coupling (UF-8) with optional "Left Side Coupling for Hub Nut Axle".*
- *Fits tire size between 22 x 1-3/8" and 700 x 40c. 29" tire is not compatible with this model. To use 26x1.5" or smaller tire, install the supplied Small Wheel Adaptor.*
- *Some assembly required. Use correct tools (10mm spanner & M4 hex wrench). Tools are not supplied in the kit.*
- *Use the supplied rear quick release skewer for maximum stability. Minoura is not responsible for any problem caused from using your own skewer.*
- *Use on flat and level floor or ground for your safety.*
- *Adjust the roller pressure to the rear tire properly in order to maximize your tire life. Tire and roller contact will eventually wear both your tire and the trainer roller.*
- *Check and adjust the remote shifter cable tension when you cannot set at L or H even though you turn the shifter lever.*
- *Touching the spinning wheel and/or any other moving parts while training may cause serious injury. Keep children and pets away from the trainer when in use.*
- *It is not possible to convert the remote controllable resistance unit to the non-remote version one due to a difference in the inside mechanism.*
- *If you feel any strange noise or smell, stop using V150 immediately and contact the retailer where you purchased the V150.*
- *Any warranty will be void if you use V150 for other purpose than instructed. Minoura offers 1-year limited warranty on the resistance unit and 5-year limited warranty on the frame from the date of your purchase for any problem caused by manufacturer's defect. Any damage or problem caused by transporting process is not covered under warranty. Any damage from shipping or moving must be made to the shipping company. Read enclosed "Minoura Limited Warranty Policy" card for more detail.*

## V150-2 Schematics

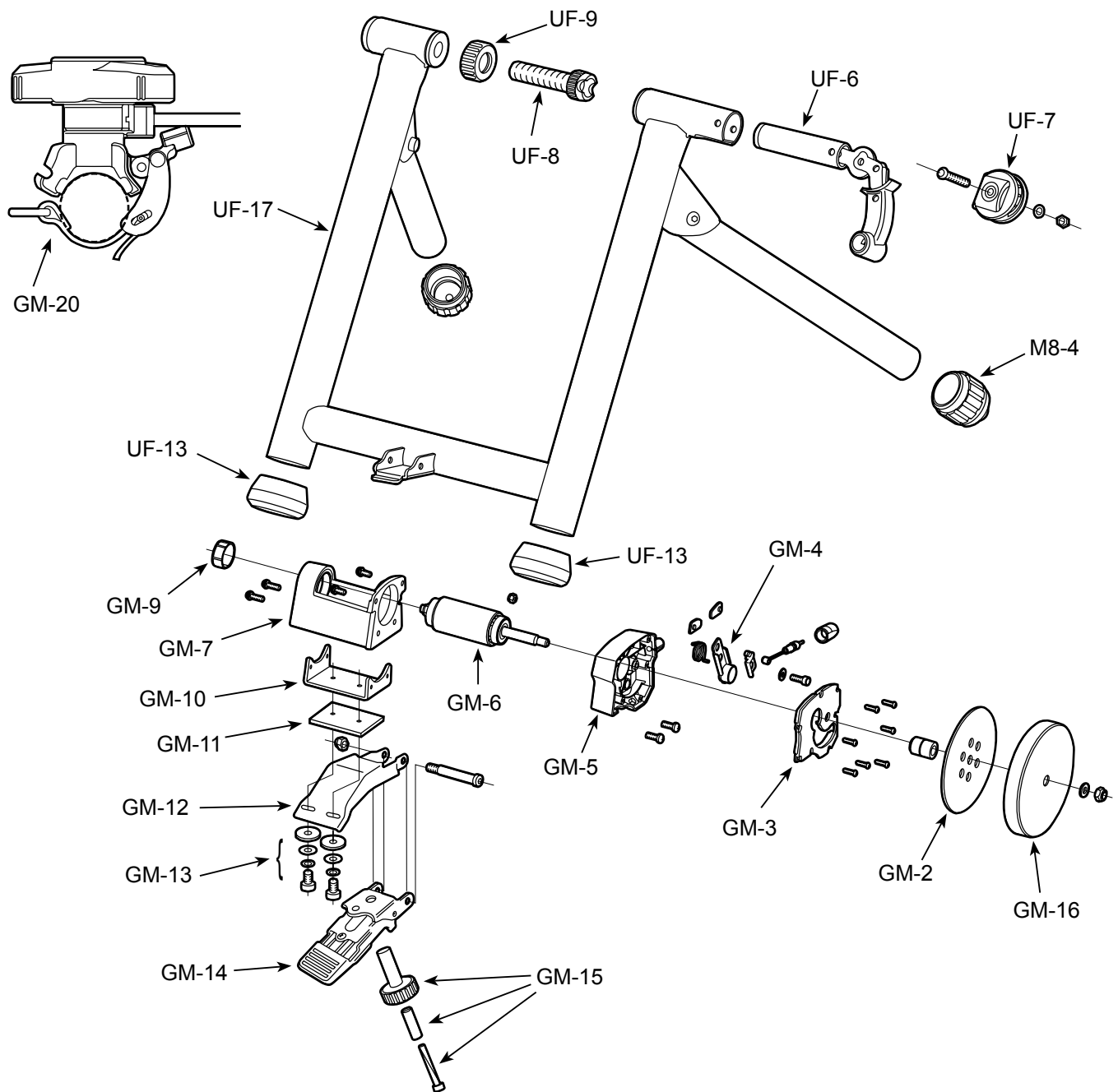

UF-6: Right Side Coupling & Clamp Lever

UF-7: Clamp Lever Guide

UF-8: Left Side Coupling

UF-9: Coupling Lock Ring (Red)

UF-13: Rubber Cap (45mm)

UF-17: V150-2 Main Frame (White)

M8-4: Rubber Foot Cap (35mm)

GM-2: Alloy Rotor

GM-3: Housing Cover

GM-4: Neodymium Magnet (for V130/150/270)

GM-5: Main Housing

GM-6: Drive Roller, Axle & Bearing

GM-7: Drive Roller Holder

GM-9: Axle End Cap

GM-10: Mag Unit Fitting Bracket

GM-11: Rubber Shim

GM-12: Mount Base

GM-13: Rubber Washer & Bolt Set

GM-14: Foot Pedal

GM-15: Micro Adjust Knob

GM-16: Flywheel (1.5 kgs for V130/150)

GM-20: Remote Shifter (Chrome Plated)

## How To Setup Your V150 Trainer

**Required Tools:** 1 x 10mm Spanner  
1 x M4 Hex Wrench

1. Replace your rear wheel quick release skewer to the supplied one.  
Minoura guarantees the stability only when using the supplied skewer due to the coupling inner shape.



*If your bike is not equipped with quick release skewer and it's a hub nut type, replace the left side coupling (UF-8) to the optional "Left Side Coupling for Hub Nut Axle".*

*Minoura doesn't guarantee the stability if you don't replace the left side coupling.*



*You don't need the supplied quick release skewer if your wheel is a hub nut type. It's not possible to convert your wheel from the hub nut type to the quick release skewer type unless replacing the hub.*

2. Install the Mag unit and the Foot Pedal (GM-14) to the frame. (see Fig. A)

Remove the pre-installed bolt from Base Plate (GM-12).  
Attach both Mag unit and Foot Pedal to the bracket on frame, align the holes, and put through the bolt.  
Tighten the bolt with 10mm spanner and M4 hex wrench.



*Do not overtighten the bolt, otherwise the Mag unit will not move smoothly even if you rotate the knob.  
If properly installed, the Mag unit will come down slowly with its own weight when you release it.*

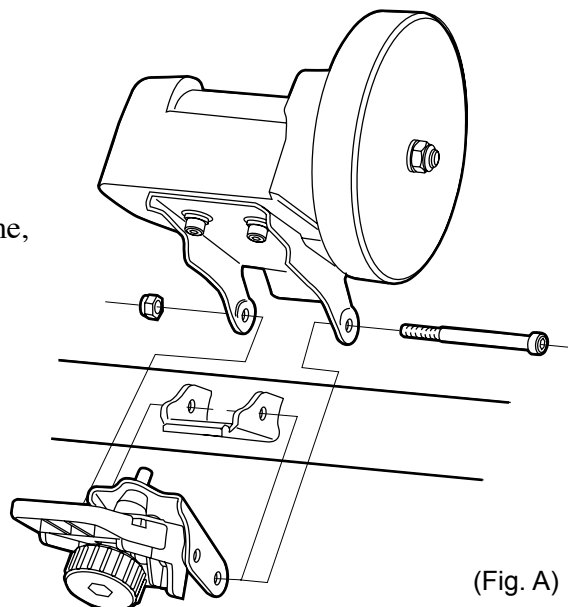

(Fig. A)

3. Fully open both legs and place V150 on a flat and level floor. (see Fig. B)

At this moment, make sure all 4 feet are contacting the floor at once to sit on the floor stable.

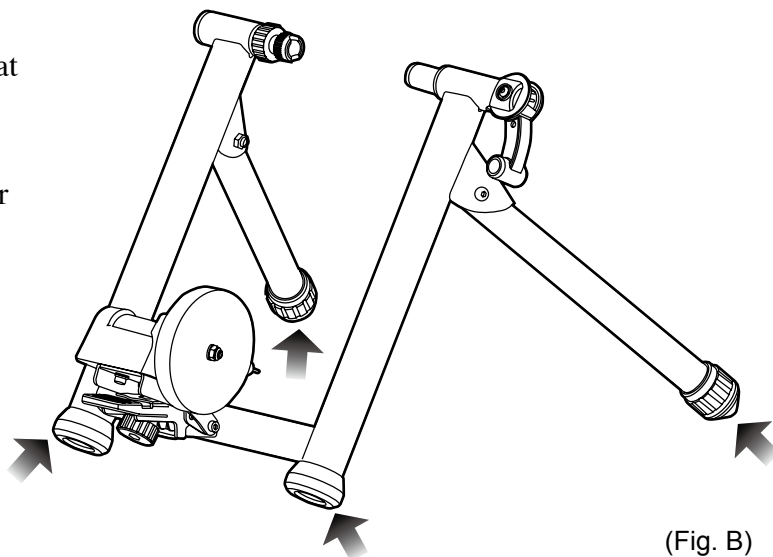

(Fig. B)

**4.** Place your rear wheel in between the couplings.

**1)** Loosen the lock ring (UF-9) to allow the left side coupling (UF-8) be free. (see Fig. C)

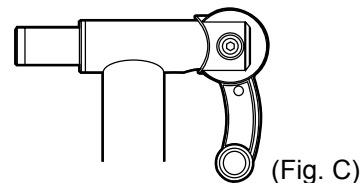
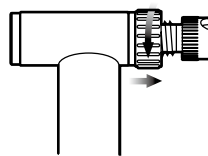

**2)** Pull up the quick hub clamp lever (UF-6) to retract the right side coupling. (see Fig. D)

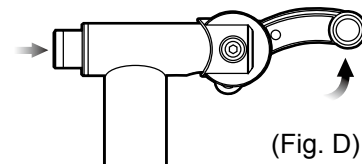
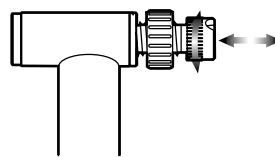

**3)** Insert the left side (quick lever side) skewer into the left side coupling first.

The quick lever shaft must be inserted into the cut-out on the coupling to hold the bike stable. Turn the coupling to adjust the cut-out position.

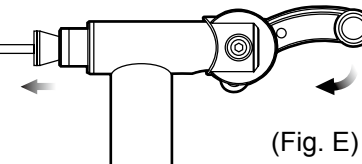
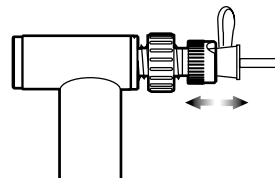

**4)** While keeping this position, slowly come down the bike to align the right side acorn nut to the right side coupling.

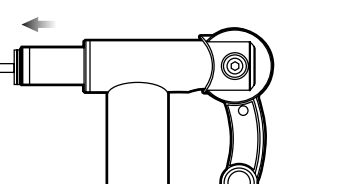
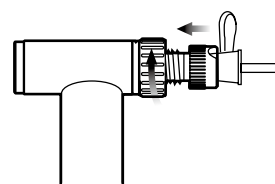

**5)** Push down the quick hub clamp lever to hold the rear wheel. (see Fig. E)

If you start feeling resistance when the lever comes at 4 o'clock position, it's correct.

If the clamping hub is too tight or too loose due to wrong position of the left side coupling, pull up the lever to release the bike, adjust the left side coupling position and try clamping the hub again.

**6)** Lastly, tighten the lock ring to fix the left side coupling position. (see Fig. F)



*Both left and right side couplings are designed to suit the supplied quick release skewer. The left side coupling must fit perfectly in the skewer head to get correct stability. (see Fig. G)*

*Any skewer type which lever is located on the end of the axle (Fig. H) or the lever will not be bent over right angle (Fig. I) cannot be used on V150.*

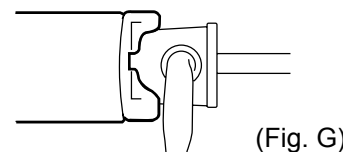

*Precisely adjust the left side coupling position to keep the correct tightness of rear hub clamping.*

*Too tight setting will cause damage to both V150 and your bike frame.*

*Too loose setting may cause the bike to come out of the trainer during use.*

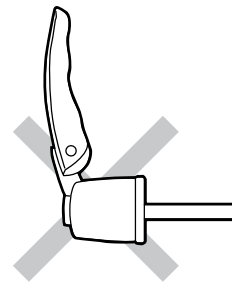
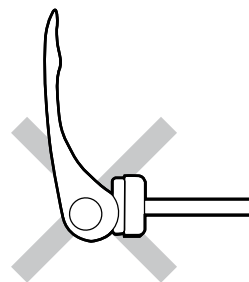

**5.** Contact the Drive Roller to the rear tire with the following steps;

- 1) Pull up the Foot Pedal to release the Mag unit lock.  
(see Fig. J)
- 2) Turn the Micro Adjust Knob clockwise until the roller comes close to the rear tire 2 - 3 mm. (see Fig. K)



*Do not make the roller touch the tire.  
Keep them separated.*

**TIPS:** *If it's hard to tighten the knob bolt, lift up the Mag unit by hand then tighten the knob.*

- 3) Push down the Foot Pedal to contact the roller to the tire.  
(see Fig. L)  
Check if the roller compresses the tire in proper depth.
- 4) To release the roller from the tire, just pull up the Foot Pedal. (see Fig. J)



*The best position is that the roller compresses the tire in the depth of 3 - 4 mm.  
Please note too much and too less roller pressure will bring premature tire wear. Keep correct roller pressure and maintain the air pressure in correct level before using V150.*

**TIPS** *Foot Pedal can repeat the same compression by just pushing down the pedal.*

**6.** The rear tire should sit in the almost center part of the Drive Roller without touching any other parts.

If the tire has touched the plastic parts due to some reasons like the rear wheel is not trued correctly or you have installed a too fat tire, you must adjust the Mag unit position.

To do so, loosen the backside screws with M5 hex wrench, adjust the roller position, then tighten the screws again tightly. (see Fig. M)

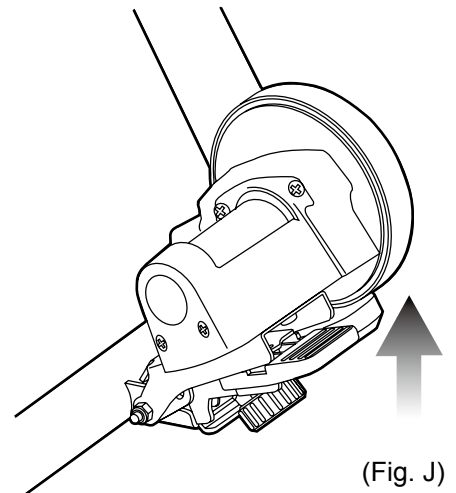

(Fig. J)

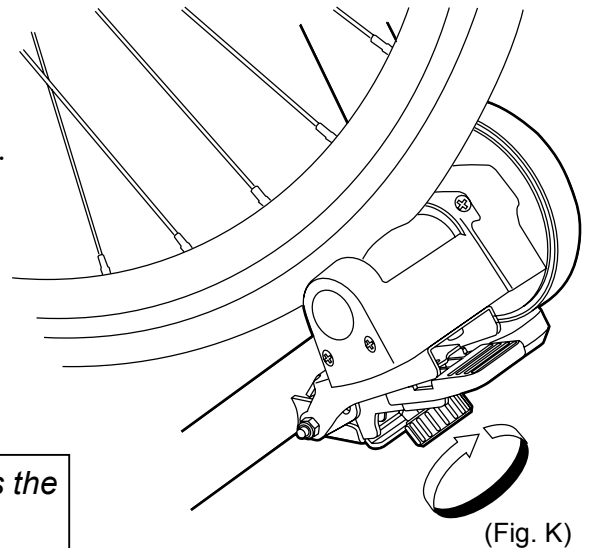

(Fig. K)

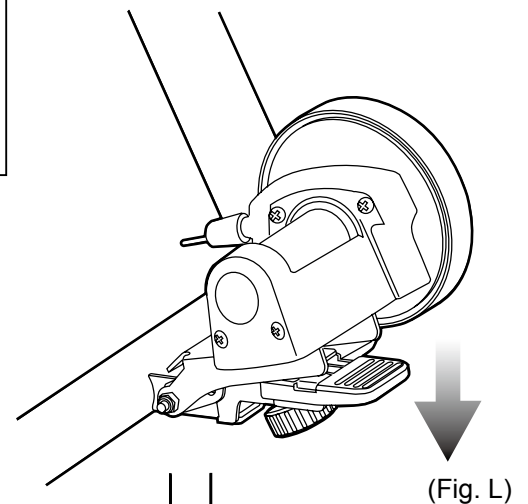

(Fig. L)

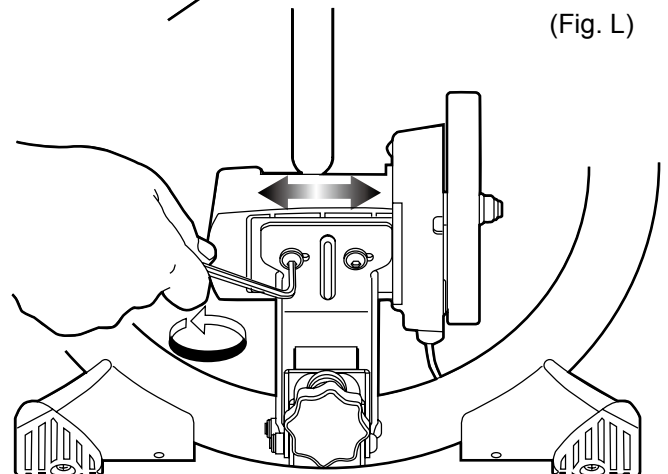

(Fig. M)



*If the rear tire has touched any other parts than the Drive Roller, the part may be damaged and your tire will wear out quickly.*



*It is impossible to adjust the rear wheel position by adjusting the left side coupling position. It just works to adjust the coupling distance.*

- 5.** To remove the bike from V150, loosen the knob then lift up on the clamp.  
If you remove the bike without changing the roller position, the next installation may become difficult because the rear wheel has been pushed forward by the roller.

## How To Adjust Resistance Level

V150 features a convenient remote shifter lever. You can install it on the handlebar or stem, then you can control the resistance level without getting off the bike.

- 1.** Wind the band around the handlebar and hook the metal ring to the gutter on the remote shifter base. (see Fig. N-1)
- 2.** Flip up the lever to lock (see Fig. N-2). If it is loosened, adjust the band tighter as per instructed in the following section.
- 3.** The soft fabric band is pre-adjusted to fit normal 22mm diameter handlebar. If you need to mount onto an oversized or specially shaped handlebar or stem, adjust the band (see Fig. O). At this moment, we suggest you to slide the guide pin downward (see the column) to loosen the band for easier work.

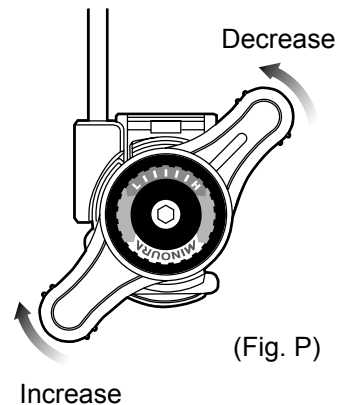
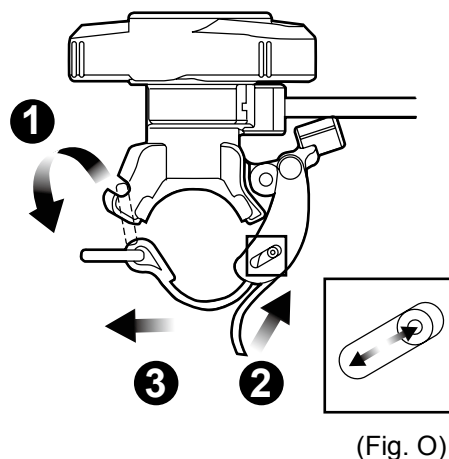
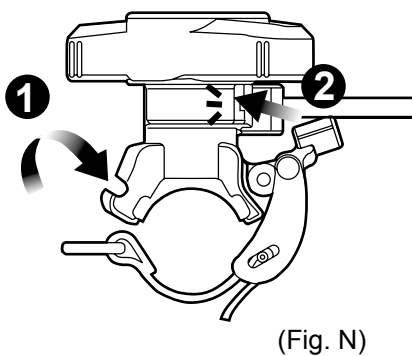

- 4.** To increase the resistance, twist the lever toward "H". To decrease the resistance, twist the lever toward "L". (see Fig. P)  
You can choose from 7 different levels to suit your desired workout level.

## Why My Remote Shifter Doesn't Work Properly?

You may have a shifting problem that you cannot set at L or H position properly due to the lengthened inner cable. To fix this problem, follow the steps to adjust the initial cable tension.

- 1.** Set your remote shifter at "H" position and remove the shifter from your handlebar, then straighten the cable as much as possible.
- 2.** Pull out the plastic cover cap on foot of the remote cable. (see Fig. Q)
- 3.** Hold the inside adjusting screw and push it toward the shifter, then adjust the locking nut to set the cable tension properly. (see Fig. R)
- 4.** Install the cover cap again.

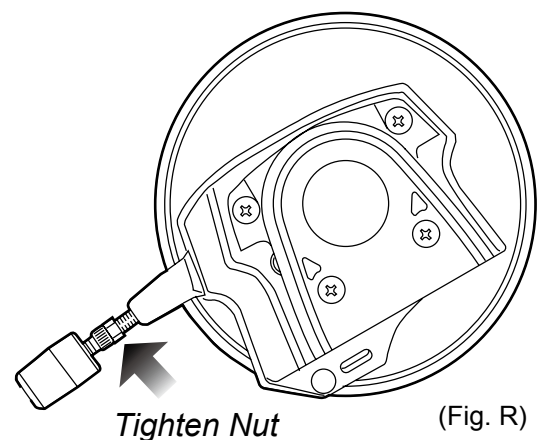
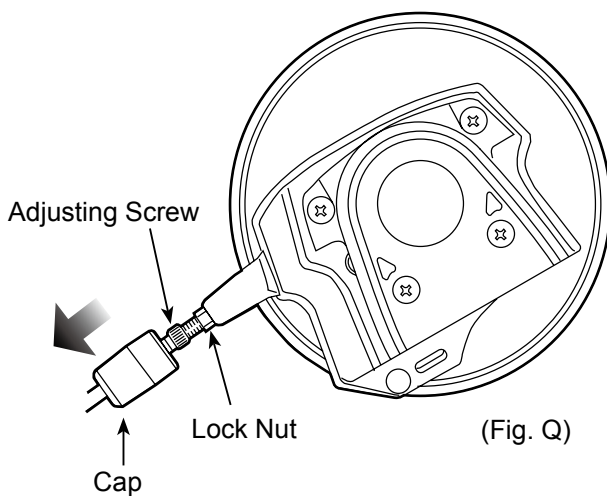

## How To Use Small Wheel Adaptor

If you wish to use the tire sized 26 x 1.5" or smaller, you need to install the supplied Z-shaped "Small Wheel Adaptor" between Base Plate and Mag unit to raise up the roller height.

The direction of Z-adaptor is fixed so follow the arrow printed on the top and make sure it's pointing toward the front (toward your bike).

If the drive roller cannot reach the tire even if you install the adaptor, make sure you have been installed in correct direction.

Use the original cap head bolts for Base Plate, and use the supplied hex head bolts for the Mag unit.

**Required Tools:** 1 x 10mm Spanner  
1 x M5 Hex Wrench

