

# MINOURA

## indoor bicycle trainer **V150** instructions manual

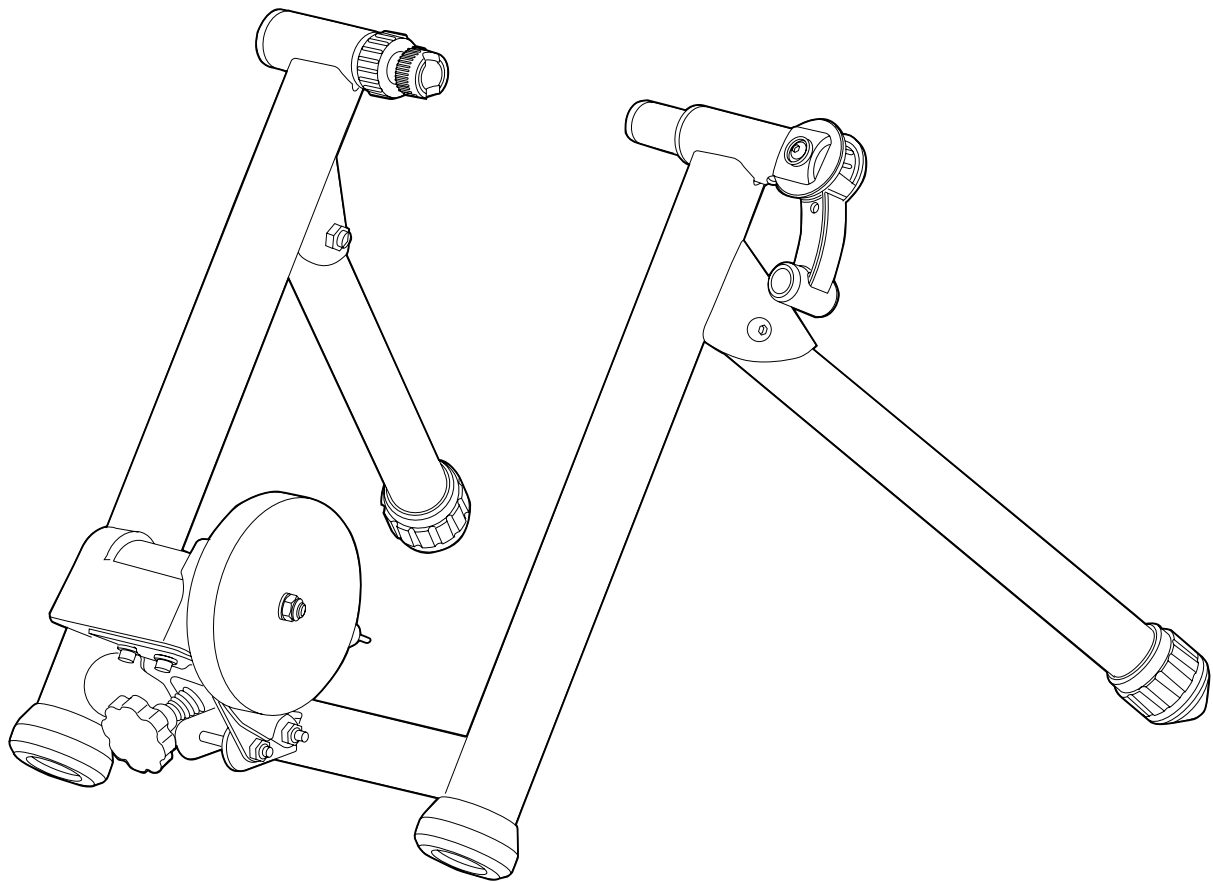

### Introduction

Thank you for purchasing the Minoura V150 indoor bicycle trainer.

The V150 incorporates a new, patent pending MAGTEQS Technology flywheel that by design is 35% more effective than other trainers in its class.

The new NEODYMIUM (neo-dee-um) magnet is four times stronger than typical ferrite magnets and offers a much wider range of resistance from low to high all while providing equal step differentials to simulate real road riding.

The new remote shifter device allows you to adjust the resistance power in 7 levels without getting off the bike and can be installed almost all diameter tubing including stem.

Read the is manual carefully and keep it for future reference.

### For More Information

*If you need help, please contact the shop first where you originally purchased this product or call the distributors in your own country. The distributors list can be found on our web site.*

#### **MINOURA NORTH AMERICA (for U.S. residents ONLY)**

1996 East Ave. Hayward, CA 94541 U.S.A.

Phone: 1-510-538-8599

Fax: 1-510-538-5899

Email: support@minourausa.com

#### **MINOURA JAPAN HEADQUARTERS (for ALL customers)**

1197-1 Godo, Anpachi, Gifu 503-2305 Japan

Phone: +81-584-27-3131

Fax: +81-584-27-7505

Email: minoura@minoura.jp

Web: www.minoura.jp

**MADE IN JAPAN**

## How To Setup V150

Required Tool: 1 x 5mm Hex Wrench (supplied)

- 1 Fully open the legs and place on a flat and horizontal floor.

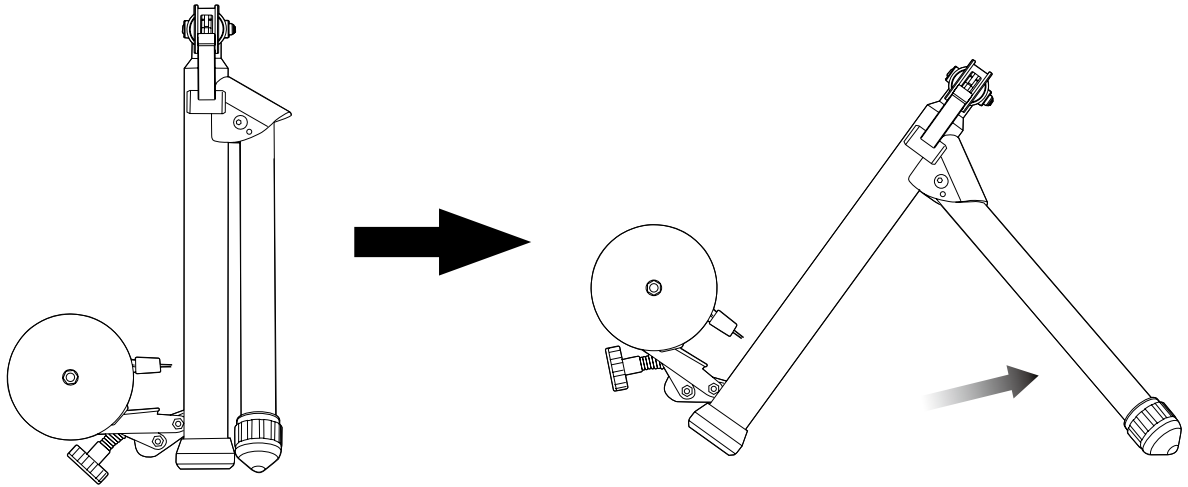

- 2 Check that all 4 points are touching the floor evenly.

If all 4 points are not touching the floor evenly the frame could bend causing damage to the trainer and possibly your bike.

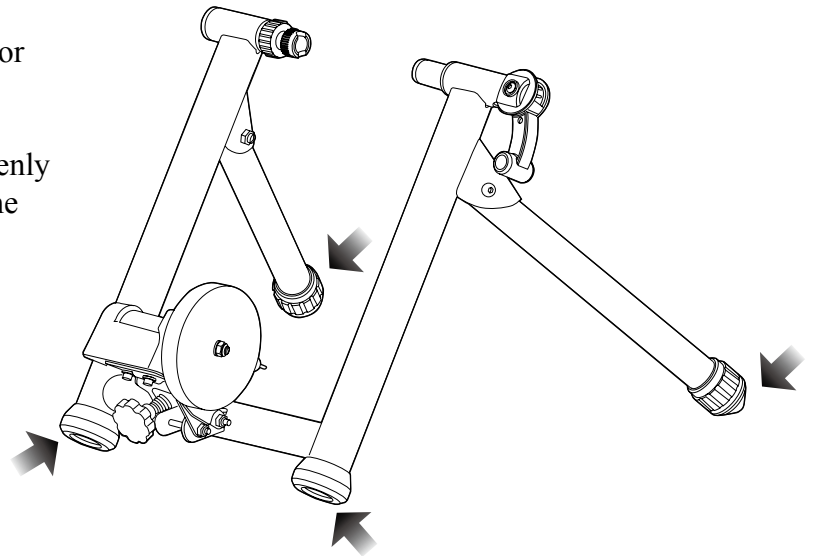

- 3 Install the Roller Pressure Knob Bolt Set to the bracket on the Step-Bar.

- 4 Install the Mag unit onto the Mount Base.



*The flywheel must be located on the right side to expect proper performance.*

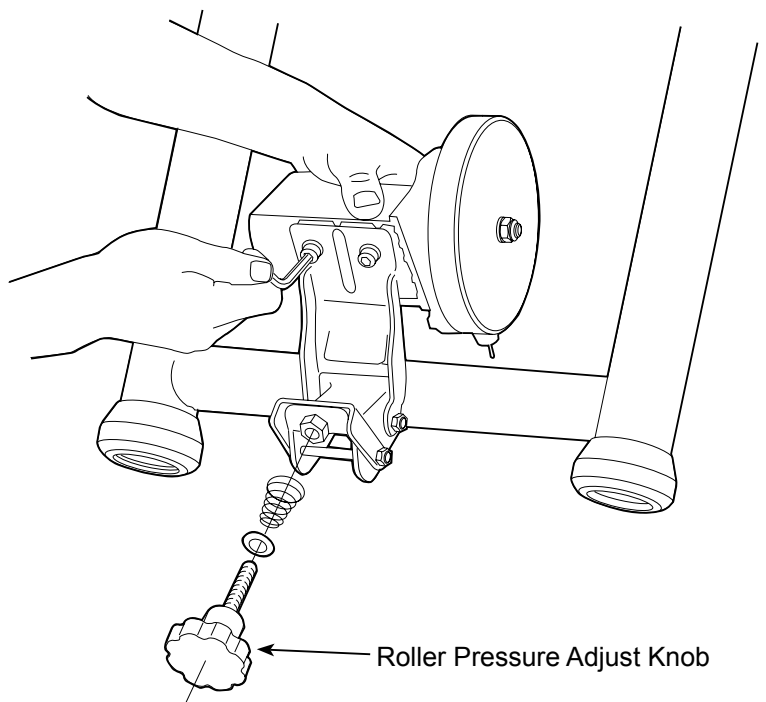

## How To Mount Your Bike

V150's coupling position is pre-adjusted in the factory to fit the 125mm standard rear hub width. If it is too loose or tight to your bike, or if you use different width of rear hub like a track race bike, adjust the left side coupling as precisely as possible for maximum stability. Please note there is no right side coupling adjustment.

**!** *The coupling cone shape is designed to fit the supplied quick release skewer perfectly. We strongly recommend you to replace your rear wheel skewer to the supplied one. We do NOT guarantee the stability while using V150 if you use your own skewer.*

**!** *If your bike's rear hub axle is not a quick release skewer type, but a hub nut type, you don't need to use the supplied skewer. Make sure the nuts of your axle fit into the couplings securely.*

*The following steps describe the micro adjustment of the left side coupling. This step is not always required and once fixed in the proper position, you should not need to adjust again. Once adjusted to fit your bike, simply operate the Quick Hub Handle Lever for a proper fit every time.*

**1** First, loosen the lock ring by turning it counter clockwise.

**2** The left side coupling is actually a bolt/coupling combination. Turn the coupling to adjust the position.

**3** Raise the Quick Hub Clamp Lever up to retract the right side coupling.

**4** Insert the left side hub end (quick release lever side) into the left side coupling cone.

**5** In this position, place the other side of the bike into the ride side coupling cone. This is the derailleur side. Make sure your derailleur cable goes OVER the coupling.

**6** Now, push down (lower) the Quick Hub Clamp Lever until it fully engages the skewer or axle nut.

**7** Make sure the Quick Clamp Hub Lever is lowered into its locked position and cannot be lowered any further. The frame may appear slightly open and this is normal. If the frame seems to be opened widely, re-mount your bike following the instructions. Failure to do so could damage your bike and/or the trainer.

**8** Now, grab the saddle of your bike and rock the bike back and forth to make sure your bike is securely in the trainer. Your bike should not move independently of the trainer where it is attached.

**9** Tighten the red Lock Ring firmly to lock the left side coupling position.

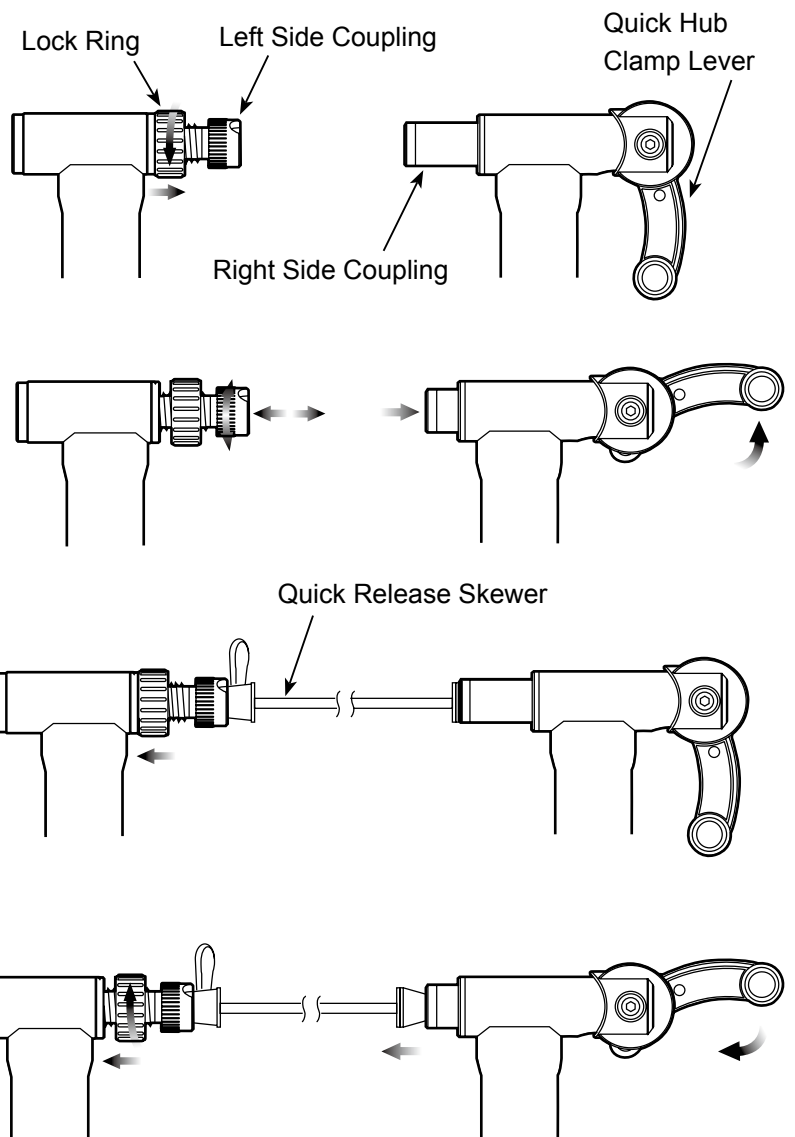

## How To Adjust Mag Unit Position

If you need to adjust the Mag unit position horizontally to set the tire in the center of the drive roller, loosen the backside screws and slide the Mag unit sideward. After adjusting, tighten both screws firmly.

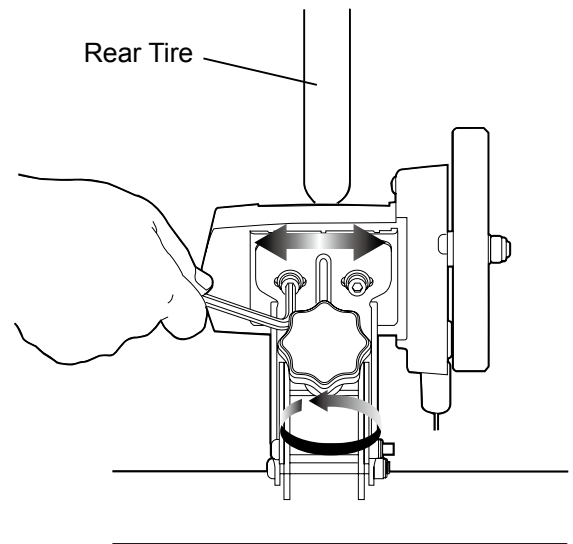

## How To Use Small Wheel Adaptor

If your tires is a 26" and smaller than 1.75" in width, you will need to use the Z- adaptor (supplied).

The direction of the Z-Adapter is fixed so follow the arrow printed on the top and make sure it's pointing toward the front (toward your bike). If the drive roller can't reach the tire, make sure the Z-Adapter has been installed correctly.

Use the original cap head bolts for the Mount Base, and use the supplied hex head bolts for the Mag unit.

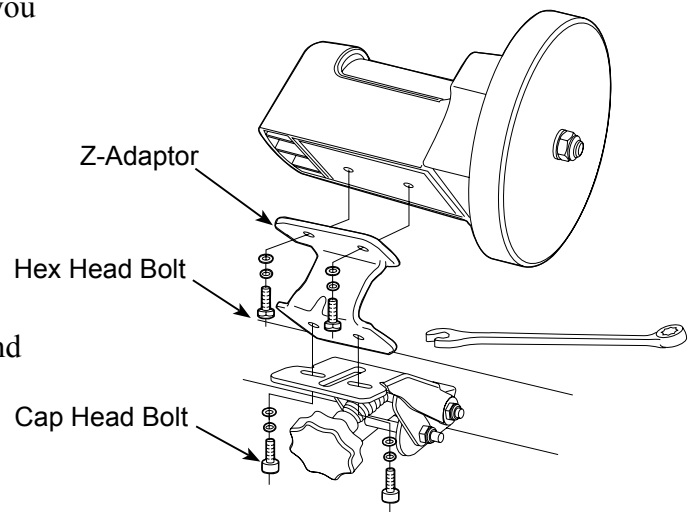

## How To Adjust Roller Pressure

*This requires every time you use V150.*

- 1** Turn the Roller Pressure Adjust Knob in the direction of clockwise until it touches the tire surface.
- 2** Turn the knob 2 - 3 rotations more to compress the tire by the roller in the depth of 3 - 4 mm.
- 3** Now, hop on your bike and give it a spin. If your tire slips, tighten the knob in 1/4 turns until the contact is correct. If the tire drags or you smell burning rubber, back off contact in 1/4 turns until you achieve proper contact.

**!** *If the roller pressure is not adjusted properly, premature tire wear can be expected. Too little pressure is worse than too much pressure for good tire life.*

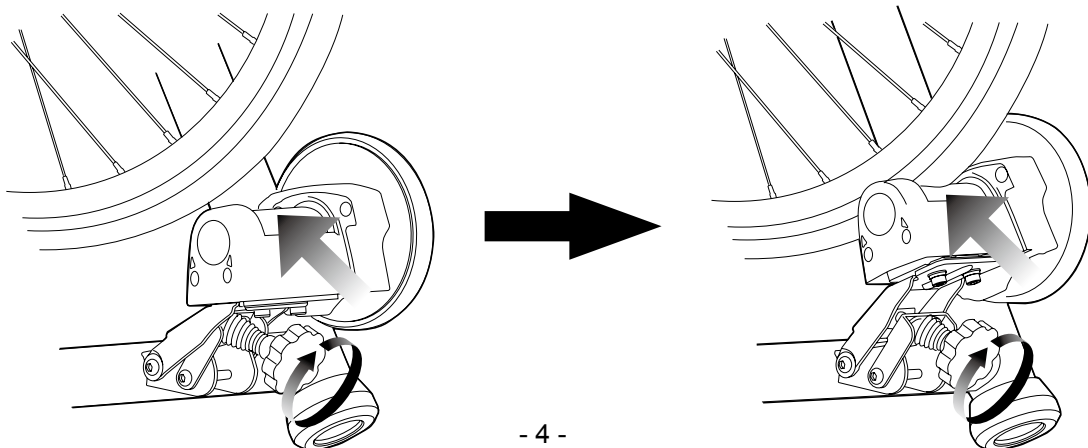

## How To Operate Remote Shifter

V150 comes with a convenient remote shifter device. By installing it on your handlebar or stem, you can adjust the resistance level without getting off the bike. The remote shifter should be used in conjunction with the gears on your bike to achieve maximum efficiency in your workout.

### How to install the remote shifter

- 1) Wind the soft fabric band around the handlebar
- 2) Hook the metal ring to the gutter on the plastic shifter base
- 3) Flip up the lever to lock

### How to increase the resistance level

Twist the shifter lever toward "H" symbol

### How to reduce the resistance level

Twist the shifter lever toward "L" symbol



*"L" is not 0 resistance. There is still some resistance at "L".*

The remote shifter is pre-adjusted to fit the standard handlebar size; 22mm (7/8") diameter.

If it becomes loose or too tight, or you need to install the shifter onto an oversized handlebar or stem, adjust the fabric band length.

At this moment, you should pull down the guide pin for easier job to loosen the band.

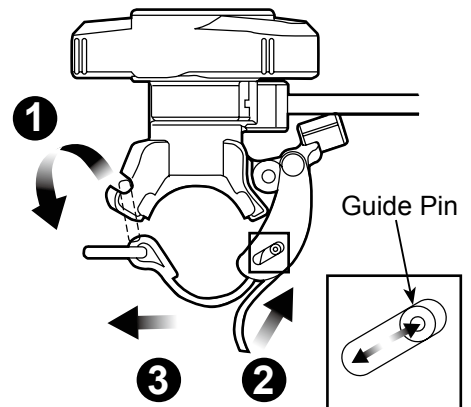
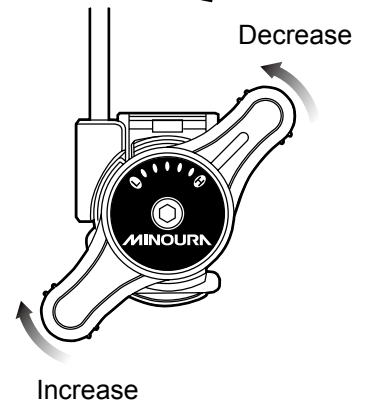
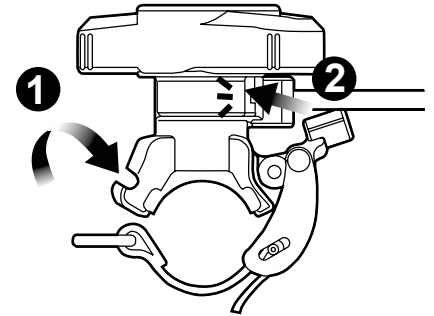

## How To Adjust Remote Cable

If you cannot shift at L or H position, it's time to adjust the remote cable.

- 1) Set the remote shifter lever at "H" position.
- 2) Pull off the black plastic cap on foot of the cable, then the adjusting screw appears.
- 3) While pushing the outer cable toward the shifter, push the adjusting screw to the cable.
- 4) Turn the lock nut until it touches the Mag unit.
- 5) Insert the plastic cap again.

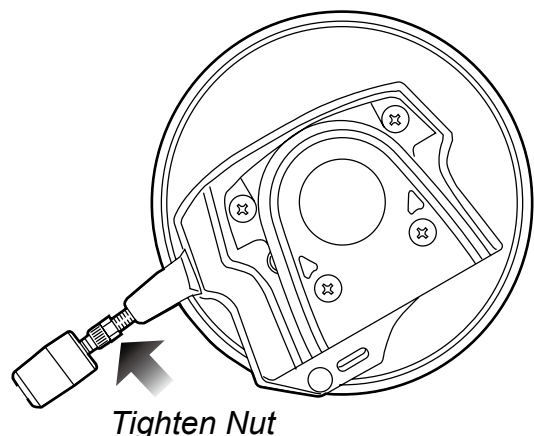
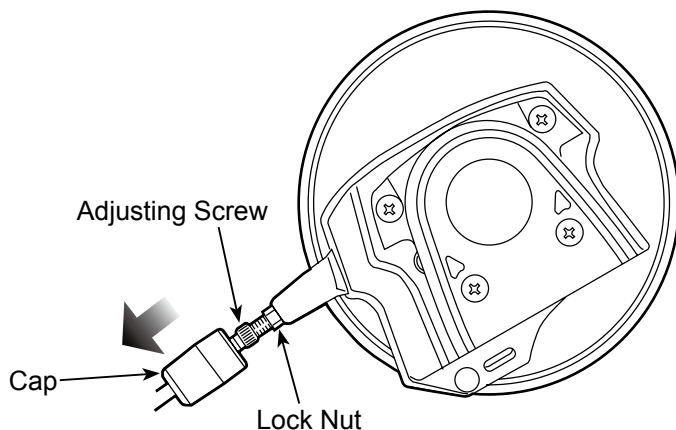

# Schematics

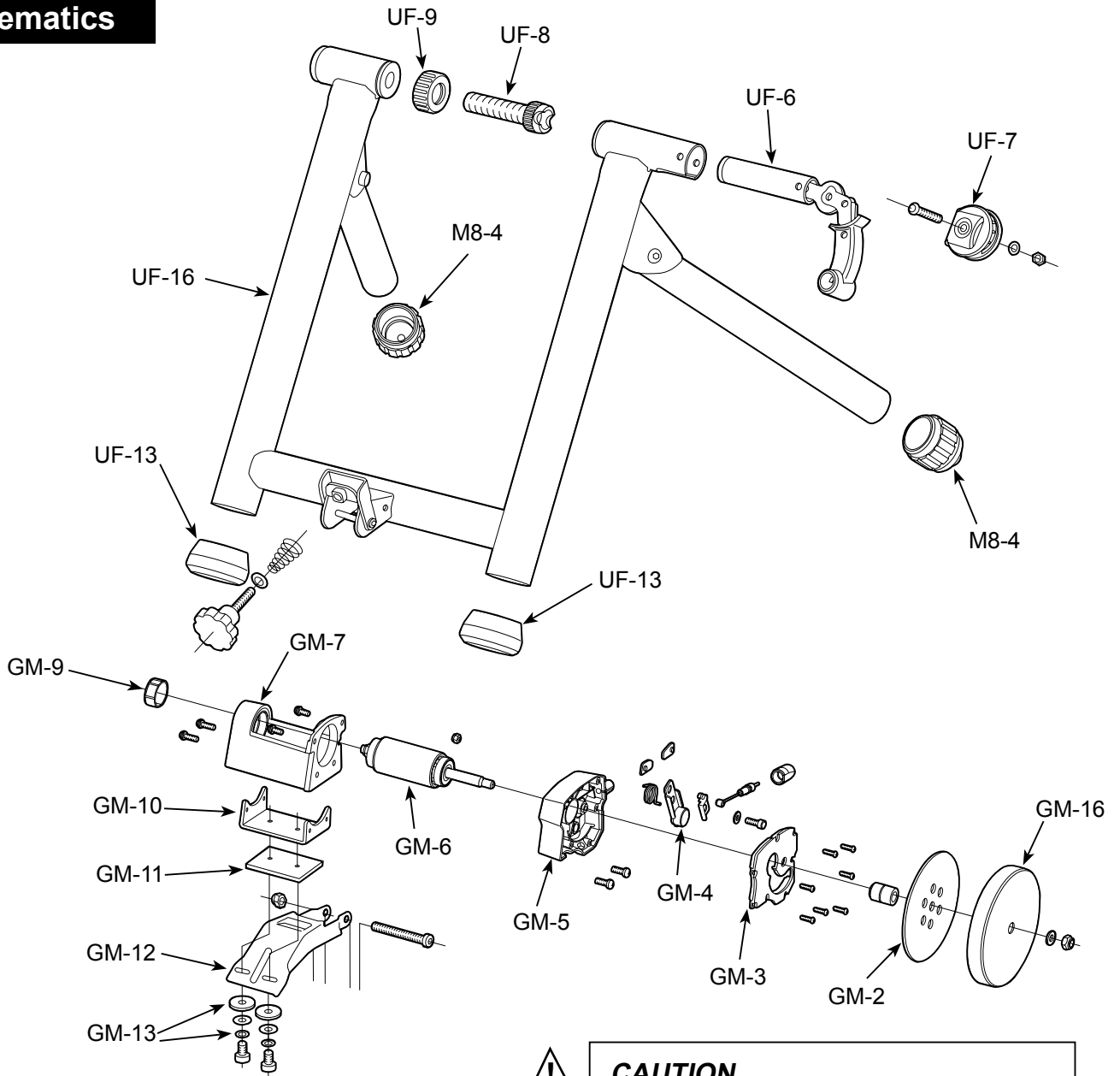

## CAUTION

Do NOT touch GM-2 "Alloy Rotor" during and 15 minutes after workout. It is VERY HOT.

- UF-6 : Right Side Coupling & Clamp Lever
- UF-7 : Clamp Lever Guide
- UF-8 : Left Side Coupling
- UF-9 : Coupling Lock Ring
- UF-13 : Ruber Cap (45mm)
- UF-16 : V150 Main Frame
- M8-4 : Rubber Foot Cap (35mm)

- GM-2 : Alloy Rotor
- GM-3 : Housing Cover
- GM-4 : Neodymium Magnet
- GM-5 : Main Housing
- GM-6 : Drive Roller, Axle & Bearing
- GM-7 : Drive Roller Holder
- GM-9 : Axle End Cap
- GM-10 : Mag Unit Fitting Bracket
- GM-11 : Rubber Shim
- GM-12 : Mount Base
- GM-13 : Rubber Washer Set
- GM-16 : V150 Flywheel