

V100/V130 Schematics

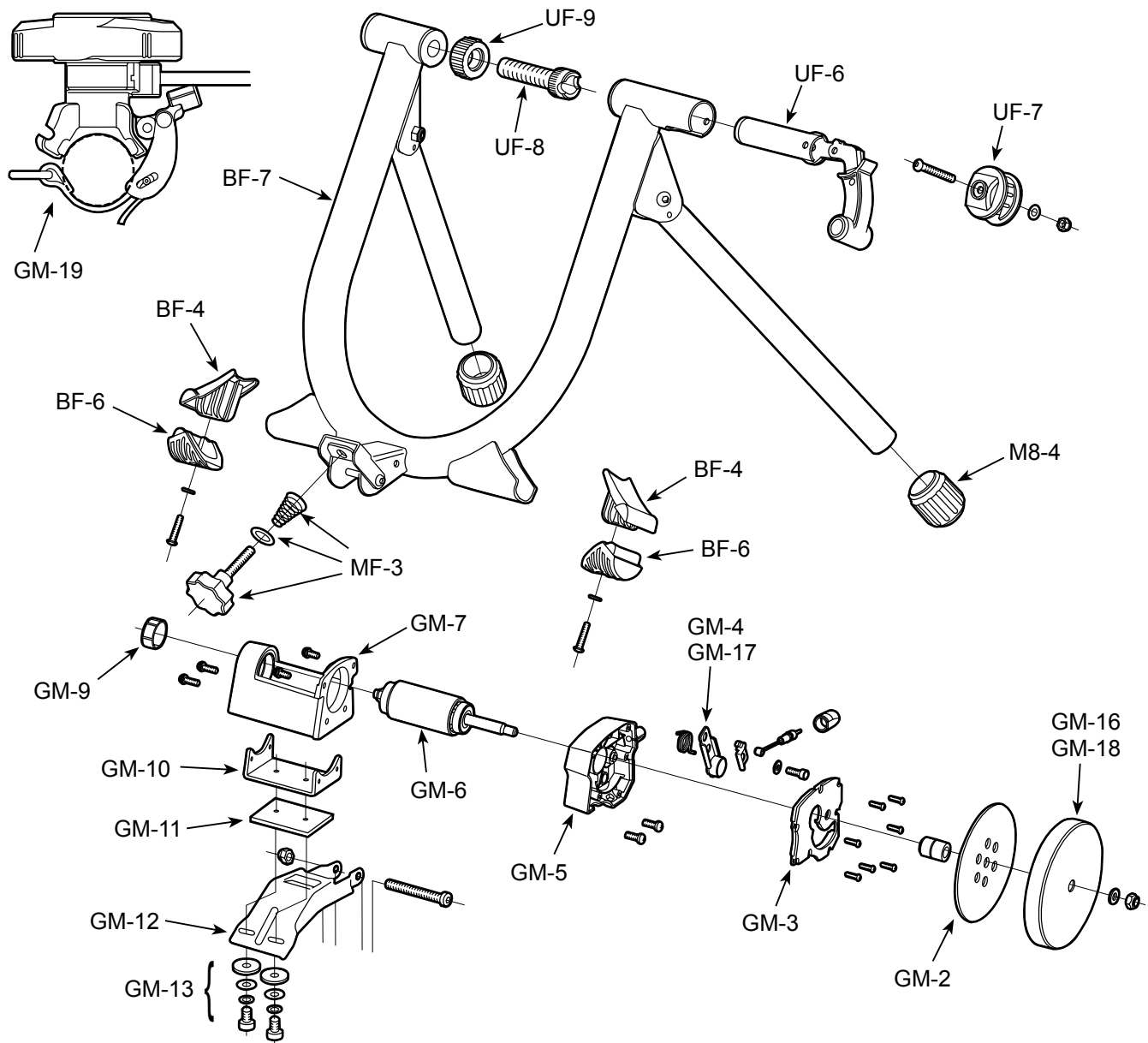

- | | |
|---|------------------------------------|
| BF-4: Leg Rubber Cover (Red) | GM-5: Main Housing |
| BF-6: Leg Rubber | GM-6: Drive Roller, Axle & Bearing |
| BF-7: V100/V130 Main Frame (Gray) | GM-7: Drive Roller Holder |
| UF-6: Right Side Coupling & Clamp Lever | GM-9: Axle End Cap |
| UF-7: Clamp Lever Guide | GM-10: Mag Unit Fitting Bracket |
| UF-8: Left Side Coupling (for Q/R skewer) | GM-11: Rubber Shim |
| UF-9: Coupling Lock Ring (Red) | GM-12: Mount Base |
| M8-4: Rubber Foot Cap (35mm) | GM-13: Rubber Washer & Bolt Set |
| MF-3: Roller Pressure Adjust Knob | GM-16: Flywheel (1.5 kgs for V130) |
| GM-2: Alloy Rotor | GM-17: Neodymium Magnet (for V100) |
| GM-3: Housing Cover | GM-18: Flywheel (1.1 kgs for V100) |
| GM-4: Neodymium Magnet (for V130) | GM-19: Quick Remote Shifter (Red) |