

Thank you for purchasing the Minoura RS-5000 bicycle repair stand.

The RS-5000 holds your bike by clamping the seat post or frame to make repairs and maintenance much easier. In addition, the RS-5000 is made of lightweight aluminum alloy tubing and foldable design with quick release skewers, so you can transport this stand anywhere you need then it becomes your work space.

The clamp jaws rotate a full 360 degrees so you can work on specific areas of your bicycle.

We recommend you to maintain your bike everytime before you ride with using this stand for your safety.

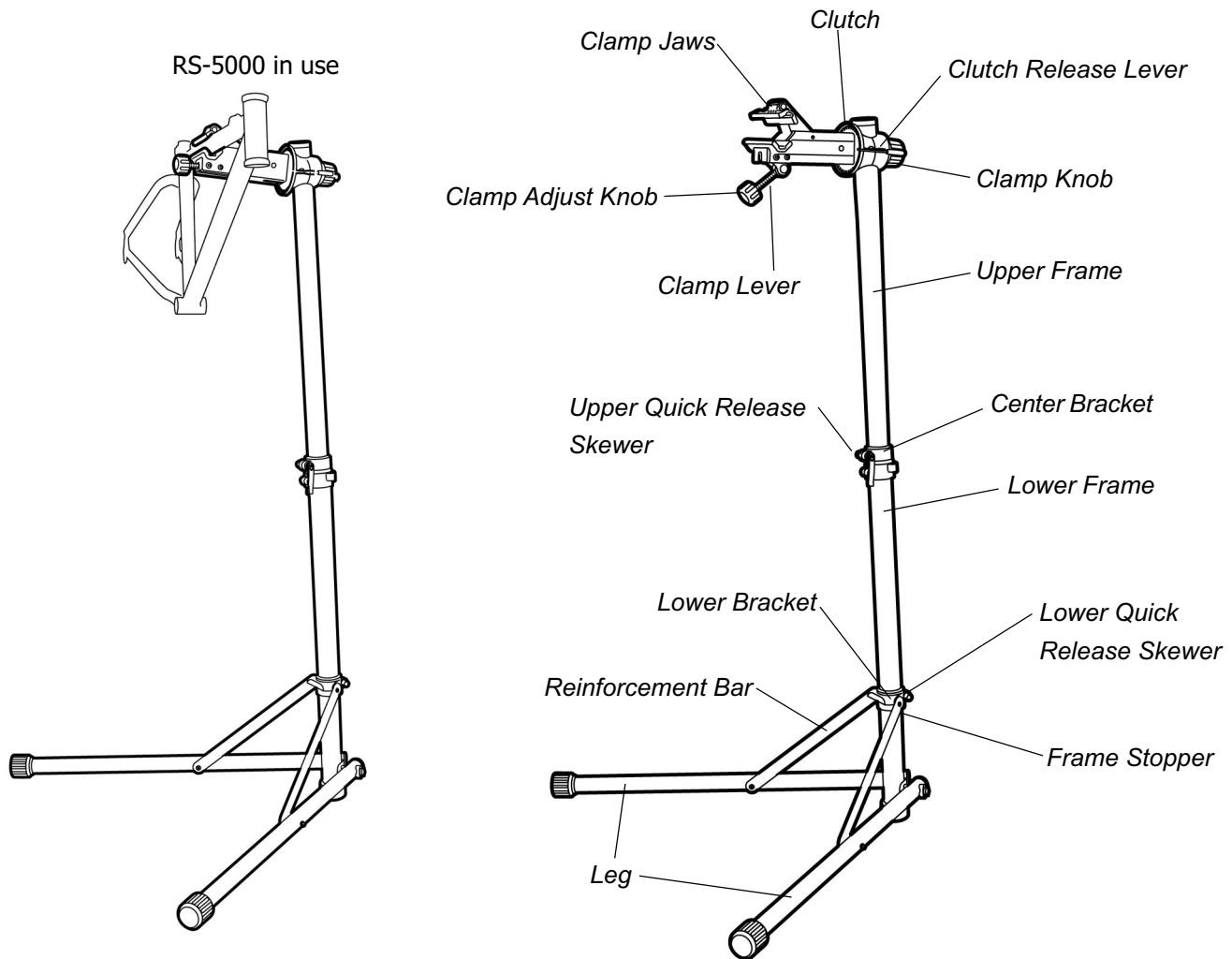

HOW TO SET-UP YOUR RS-5000

The RS-5000 is already fully assembled so you can start using this stand within a minute.

To set-up your RS-5000, follow these steps;

- 1** Loosen the Lower Quick Release Skewer and open the Legs by sliding down the Lower Bracket until it touches the Frame Stopper. (see Fig. A)

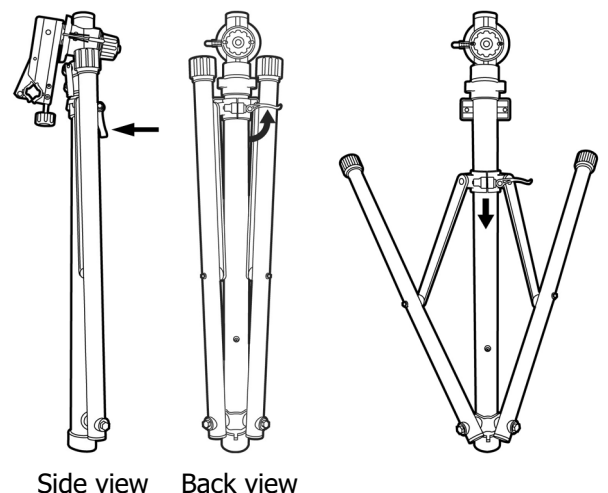

Side view Back view

(Fig. A)

 *When you open the Leg, be sure you place your hand away from the area where the Lower Bracket comes down to prevent from the problem of pinching your hand or finger by the bracket or the Reinforcement Bar. (see Fig. B)*

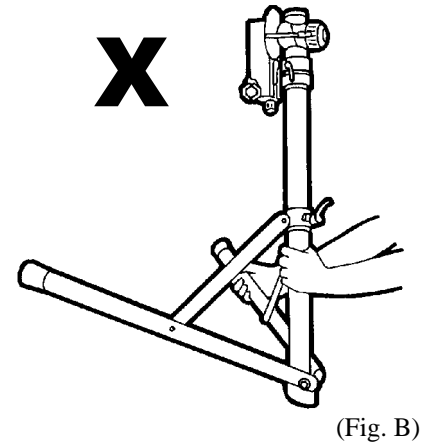

 *You may open the Legs in wrong direction as shown in Fig. C. This position cannot hold the bike properly so you must make sure you open the Legs in the right direction. The Legs must be opened in the direction of the Clamp Jaws.*

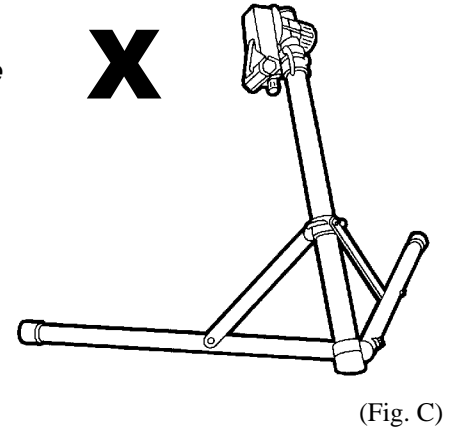

2 After completing opening the Leg, tighten the Lower Quick Release Skewer firmly to fix the position. (see Fig. D & E)

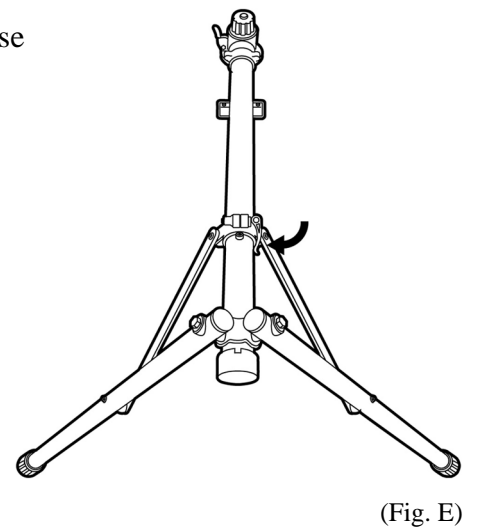
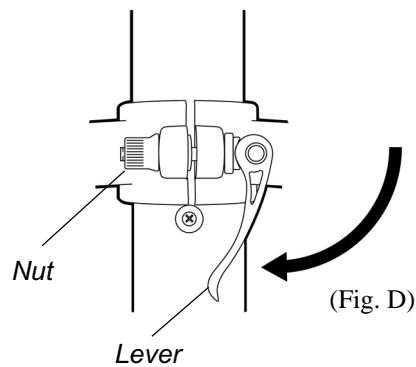

 *If the skewer is loosened, the frame may slide down by the weight of the bike during use and it may cause an accident. To avoid this problem, you must tighten the skewer perfectly with the following steps;*

- 1.** Tighten the Nut until you feel some resistance when you push down the Lever at the half position.
- 2.** Then strongly push down the Lever by your palm (not your finger) until the Lever positions downward. (see Fig. F)

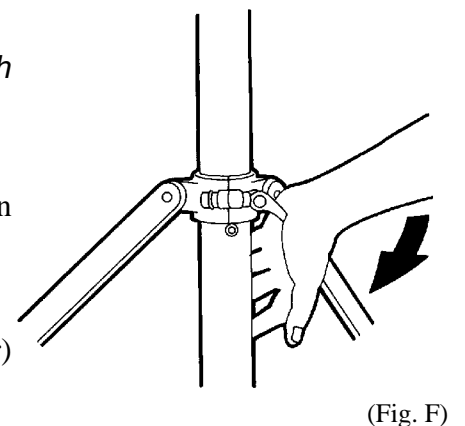

3 Loosen the Upper Quick Release Skewer and pull out the Upper Frame from the Lower Frame. (see Fig. G & H)

Lengthen the Upper Frame as you need (see Fig. I), then fix its position with tightening the Upper Quick Release Skewer.

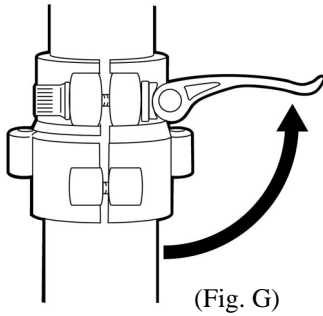

(Fig. G)

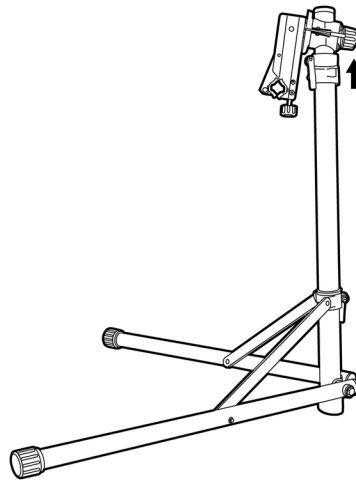

(Fig. H)

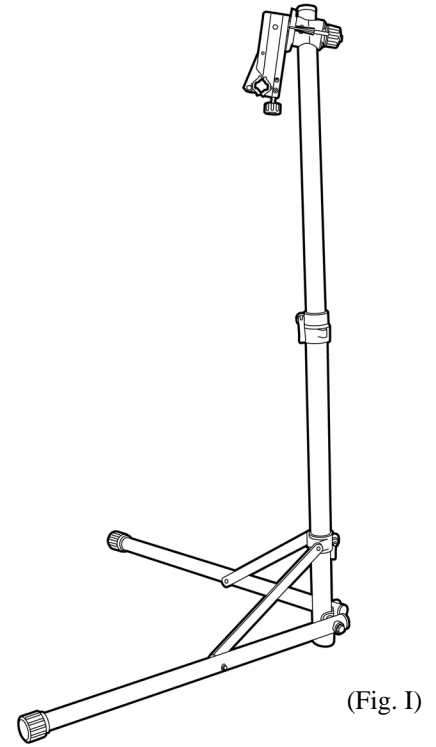

(Fig. I)

 Do not set the Q/R lever as per Fig. J as it may be caught during use and cause the stand to collapse. So we recommend you to set the lever as shown in Fig. K or down the lever along the frame.

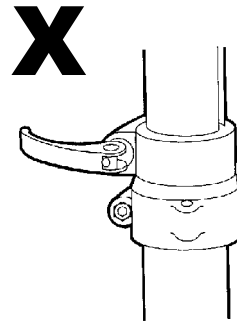

(Fig. J)

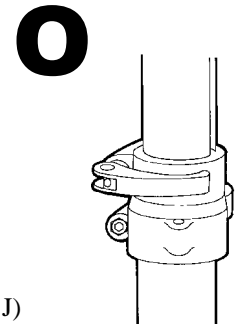

(Fig. K)

4 Fully loosen the Clamp Knob, raise the Clamp Jaws and insert it fully into the square section on the metal bracket (see Fig. L). Be sure there is only one direction where the Clamp Jaws can be inserted.

Then tighten the Clamp Knob again to hold the position. (see Fig. M)

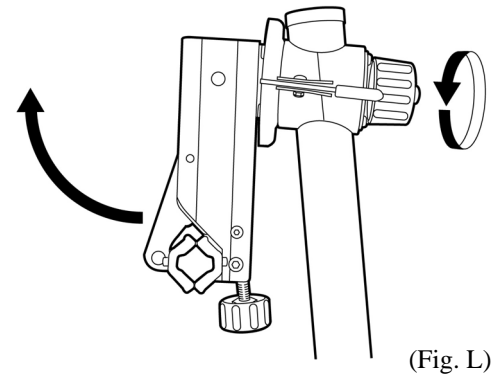

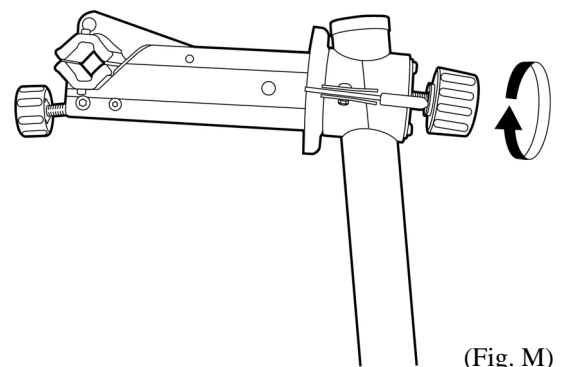

(Fig. L)

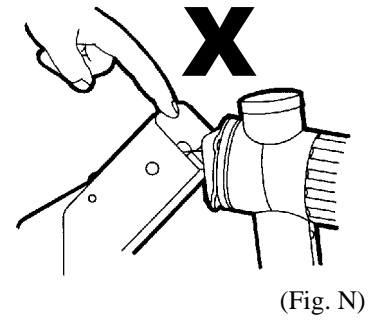

(Fig. M)

 At this time, be careful do not pinch your finger between the Clamp Jaws and the Metal Bracket. (see Fig. N)
Also the inside edge of the Clamp Jaws may be sharp and you may cut your finger there. Do NOT touch the edge.



 If the Clamp Jaws is not fully inserted, you can see the Clamp Jaws lies down slightly.
This means the clamp cannot hold the weight of the bike enough and it may be broken or cause an accident, so you must make sure if the Clamp Jaws is set perfectly. (see Fig. O)

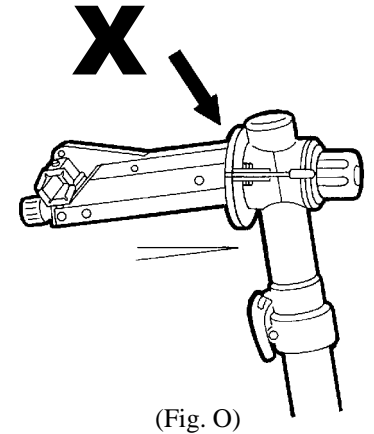

HOW TO CLAMP YOUR BIKE ON THE RS-5000

1 Place the RS-5000 on flat and horizontal floor or the ground. (see Fig. P)
And make sure if the Lower Bracket reaches the Stopper (see Fig. Q). Otherwise the stand will be unbalanced.

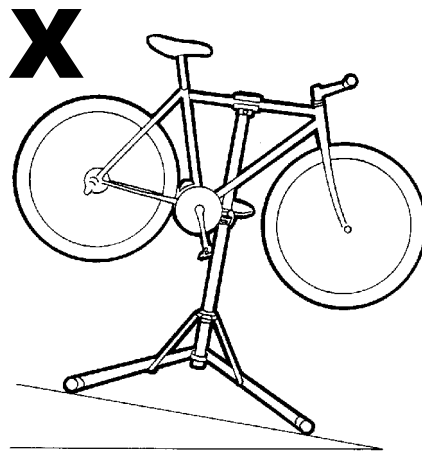

(Fig. P)

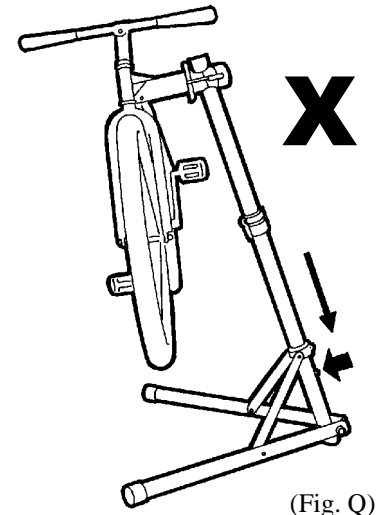

(Fig. Q)

2 To adjust the angle of the Clamp Jaws, loosen the Clamp Knob a few turns, push the Clutch Release Lever and rotate the Clamp Jaws. (see Fig. R)
When you complete at your desired angle, release the Clutch Release Lever with confirming the edge of the lever is fully bitten by the teeth of the Clutch, then tighten the Clamp Knob again firmly.

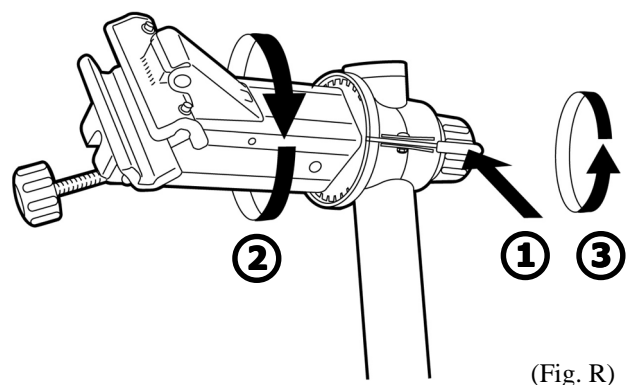

- 3** To open the Clamp Jaws, push down the Clamp Lever. (see Fig. S)
 To shut the Clamp Jaws, pull up the Clamp Lever. (see Fig. T)

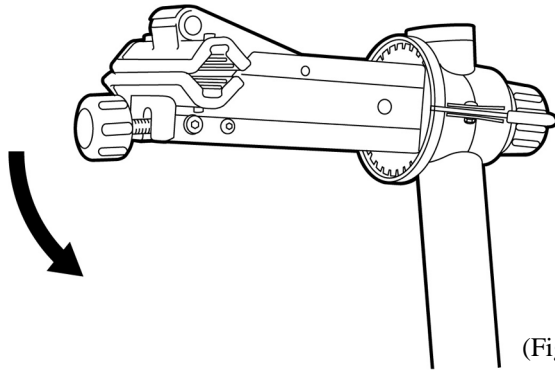

(Fig. S)

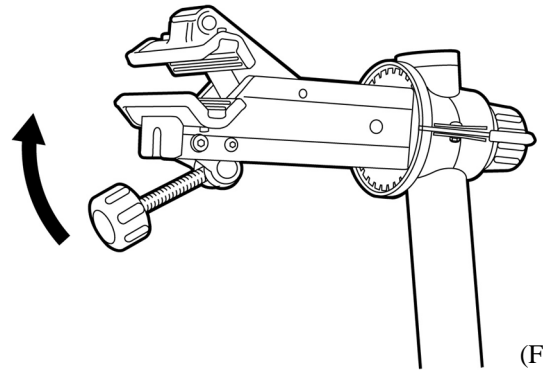

(Fig. T)



When you operate the Clamp Lever, be careful not to pinch your finger between the Clamp Lever and the Clamp Jaws. (see Fig. U)

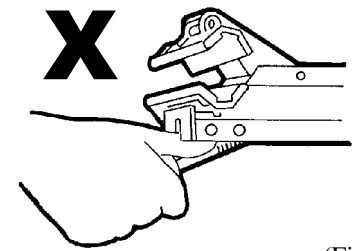

(Fig. U)

- 4** To adjust the Clamp Jaws, turn the small Knob on the Clamp Lever. (see Fig. V)

If you turn the knob in the direction of the counter-clockwise, the jaws will open wider.

If you turn the knob in the direction of clockwise, the jaws will be narrower.

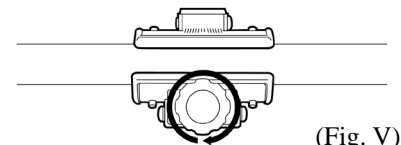

(Fig. V)

- 5** If you wish to clamp the top tube of your bike, set the Clamp Jaws horizontally in advance. (see Fig. W)

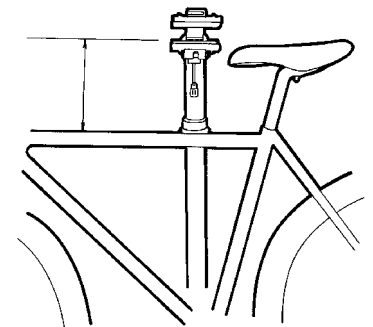

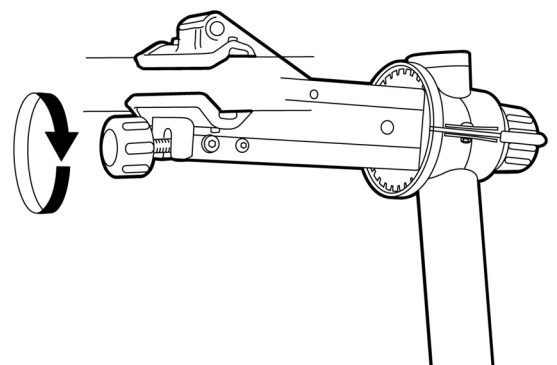

(Fig. W)

- 6** Place the top tube of your bike onto the lower jaw, fully pull up the Clamp Lever to shut the jaws, then turn the Clamp Adjust Knob on the Clamp Lever clockwise securely. It should be the proper position. (see Fig. X)



(Fig. X)

 Do not set the bike upside down as the clamp will not hold the bicycle securely in the position. (see Fig. Y)

 We don't recommend you to use the Clamp Jaws upside down (the moving part is locating lower) because the bike may fall off suddenly if the clamp is loosened.

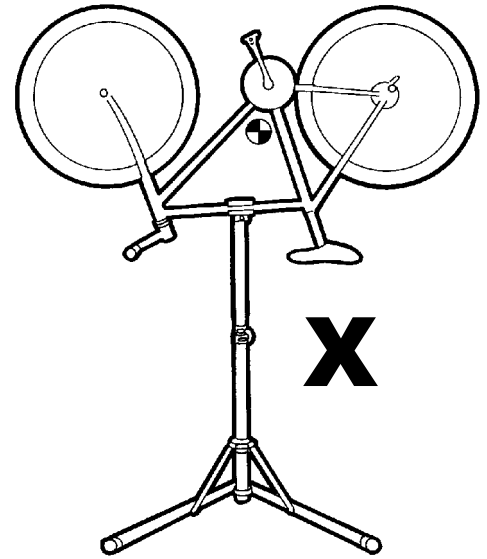

(Fig. Y)

7 If you wish to clamp the seat post or the seat tube instead of the top tube, adjust the angle of the Clamp Jaws before placing your bike. (see Fig. Z)

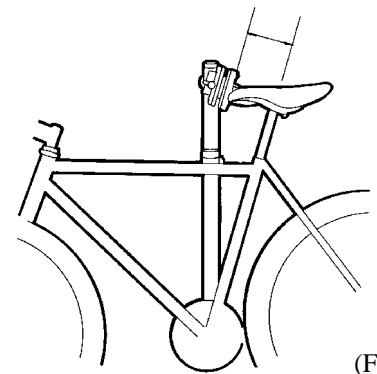

(Fig. Z)

8 Clamp the seat post firmly with referencing the above Step:6. (see Fig. AA)

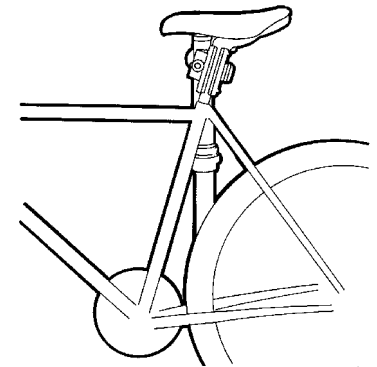

(Fig. AA)

HOW TO REPLACE THE RUBBER PAD OF THE CLAMP JAWS

The rubber clamp pad is replacable. You can order this parts at your local Minoura dealer.

1 To replace the rubber pad of the Clamp Jaws, remove both right and left E-rings with a plier. (see Fig. AB)
The E-rings are not included in the replacement kit, so you should keep the removed ones.

2 Pull out the old rubber pad and install the new one.

3 Set the E-rings.

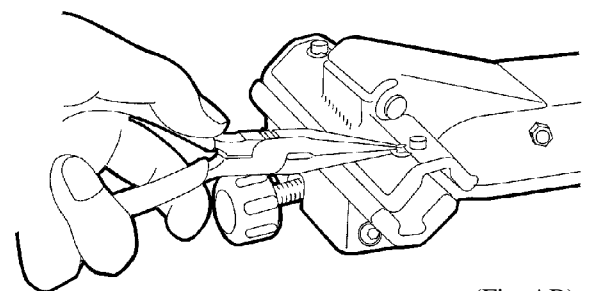

(Fig. AB)

OPTIONS

• Tool Tray

A durable plastic tray for placing the tools and the removed parts.
Installed on the top of the main frame.

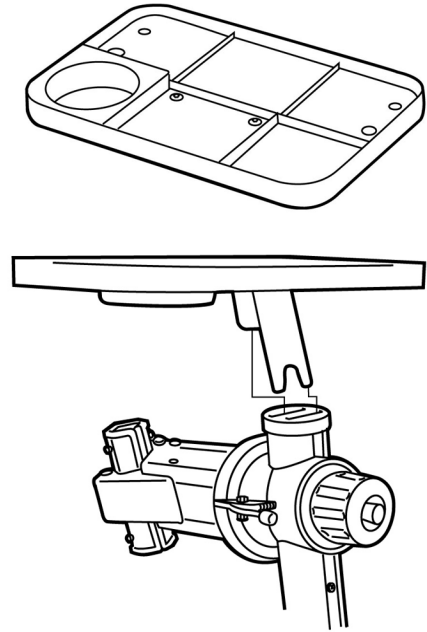

• Carry Bag

Made of durable Nylon.
Good for transporting and storage.

FOR MORE INFORMATION

Contact: *Those who purchased the W-3000 through any mail order house,
ask to their customer service department first.*

MINOURA JAPAN HEADQUARTERS

(for all customers)

1197-1 Godo, Anpachi, Gifu 503-2305 JAPAN

Fax: (+81) 584-27-7505

Email : minoura@minoura.jp

URL : <http://www.minoura.jp>

MINOURA NORTH AMERICA

(for the United States residents only)

1996 East Avenue, Hayward, CA 94541-5454 U.S.A.

Fax : 1-510-538-5899

Email : MinHelp@ATTglobal.net

MADE IN JAPAN

Copyright © 2004-2005, MINOURA CO.,LTD. All Rights Reserved.