

MINOURA

M20-V

minimag



Indoor Bicycle Trainer for mini-velo – instructions manual –

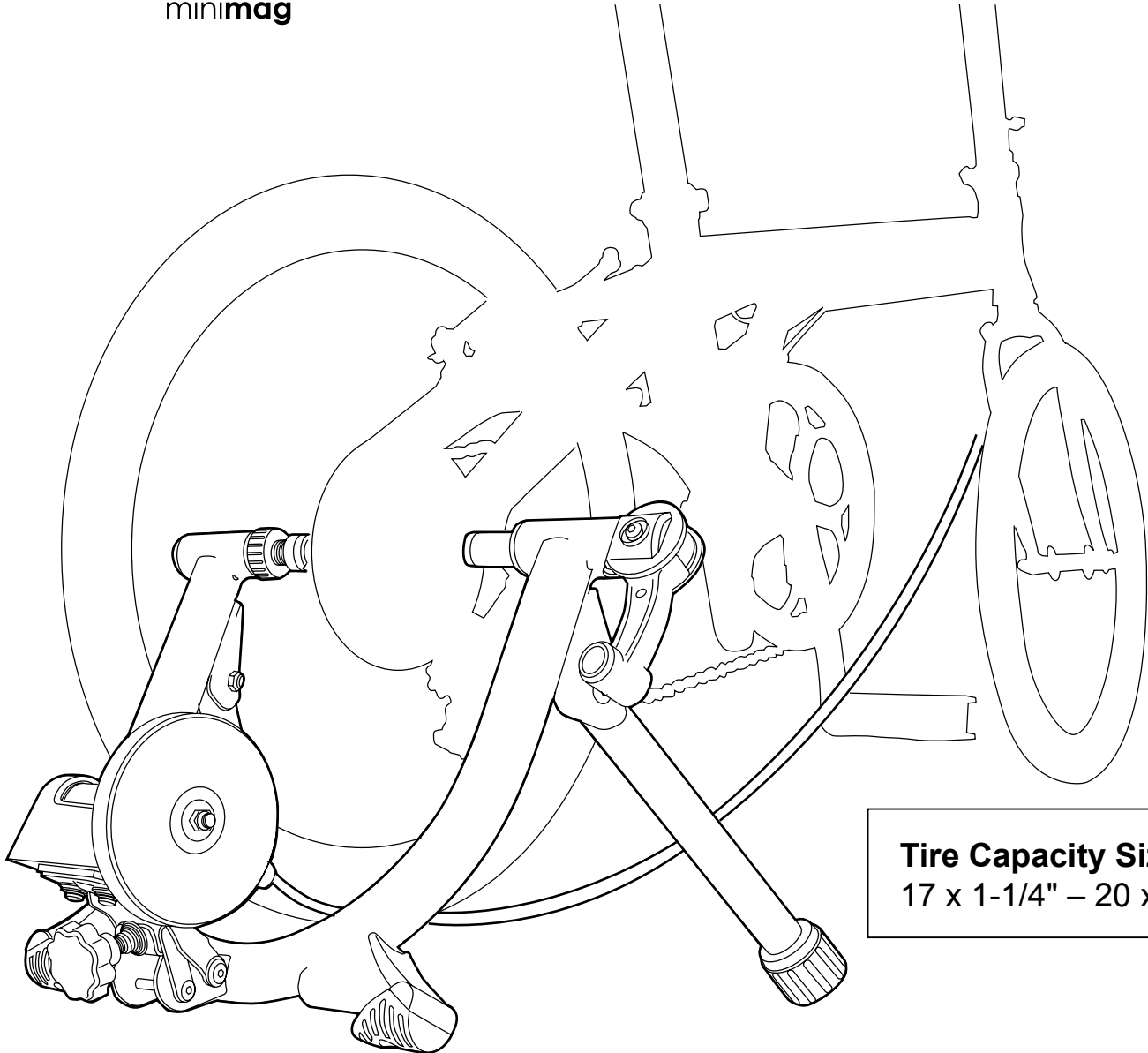

Tire Capacity Size:
17 x 1-1/4" – 20 x 1-1/8"

Read this instructions carefully before use

Minoura Japan Headquarters

(for all customers)

1197-1 Godo, Anpachi, Gifu 503-2305 Japan

Phone: +81-584-27-3131 / Fax: +81-584-27-7505

Email: minoura@minoura.jp

www.minoura.jp

Minoura North American Tech Center

(for U.S. residents only)

1996 East Avenue, Hayward, CA 94541 U.S.A.

Phone: 1-510-538-8599 / Fax: 1-510-538-5899

Email: support@minourausa.com

Made in Japan

MINOURA

(ver.1.1 2011/1)

IMPORTANT NOTICE

- *For use with mini-velo or BMX with the tire sized between 17x1-1/4 and 20x1-1/8 only.*
- *Hub nut type rear wheel axle is not compatible with M20-V in standard. You need to replace the left side coupling (UF-8) with optional "Left Side Coupling for Hub Nut Axle".*
- *Some assembly required. Use correct tools (10mm spanner & M4 hex wrench). Tools are not supplied in the kit.*
- *Use the supplied rear quick release skewer for maximum stability. Minoura is not responsible for any problem caused from using your own skewer.*
- *Use on flat and level floor or ground for your safety.*
- *Adjust the roller pressure to the rear tire properly in order to maximize your tire life. Tire and roller contact will eventually wear both your tire and the trainer roller.*
- *M20-V is a tire drive model, so if you use M20-V with a knobby tire on BMX, a loud noise must occur. To avoid this problem, replace the rear tire to a slick pattern one.*
- *Do not use M20-V for removing the mud from the tire.*
- *Touching the spinning wheel and/or any other moving parts while training may cause serious injury. Keep children and pets away from the trainer when in use.*
- *It is not possible to convert the non-remote resistance unit to the remote control version one due to a difference in the inside mechanism.*
- *If you feel any strange noise or smell, stop using M20-V immediately and contact the retailer where you purchased the M20-V.*
- *Any warranty will be void if you use M20-V for other purpose than instructed. Minoura offers 1-year limited warranty on the resistance unit and 5-year limited warranty on the frame from the date of your purchase for any problem caused by manufacturer's defect. Any damage or problem caused by transporting process is not covered under warranty. Any damage from shipping or moving must be made to the shipping company. Read enclosed "Minoura Limited Warranty Policy" card for more detail.*

M20-V Schematics

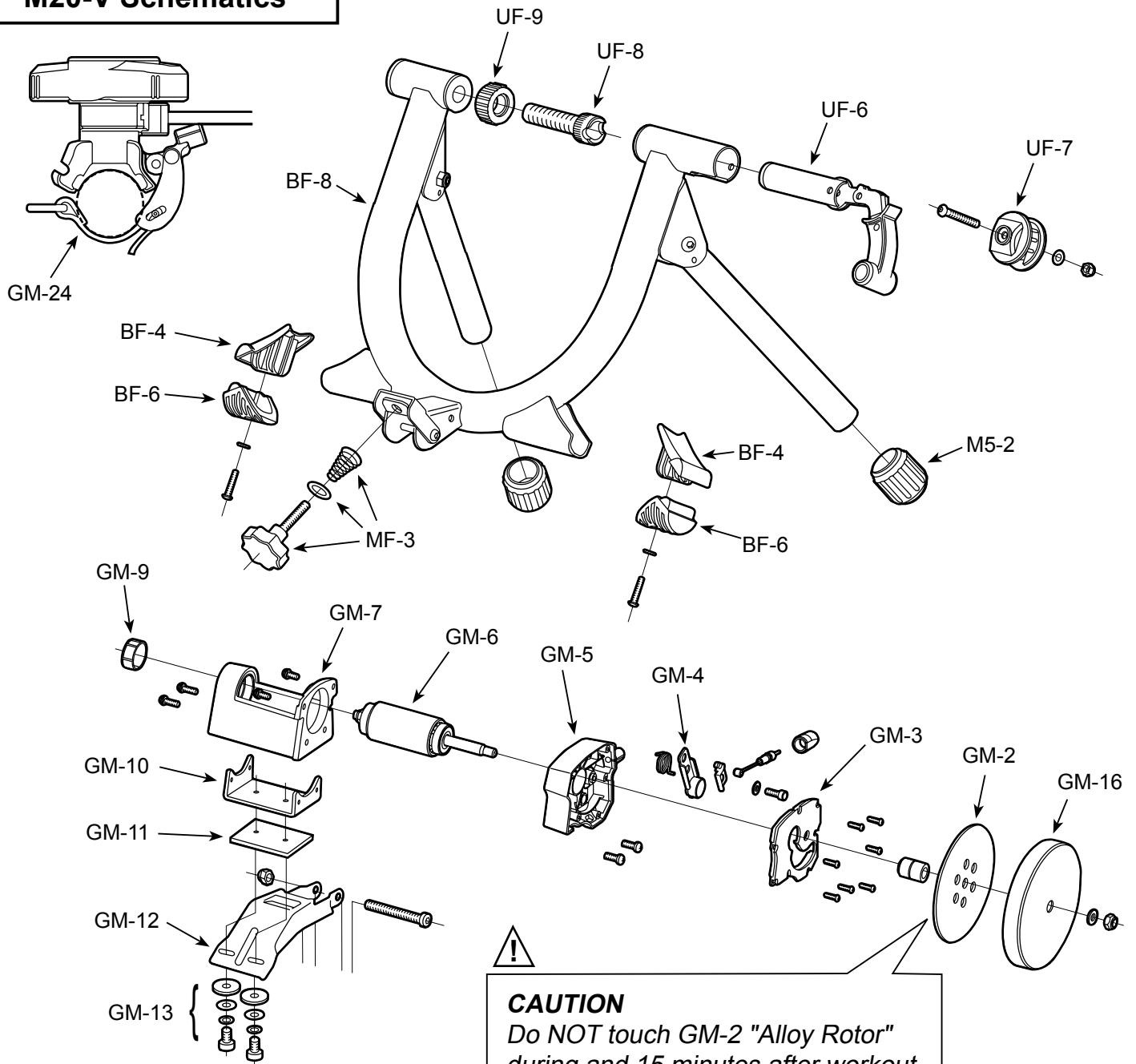

- | | |
|------------------------------------------|-------------------------------------|
| BF-4: Leg Rubber Cover (Red) | GM-4: Neodymium Magnet |
| BF-6: Leg Rubber | GM-5: Main Housing |
| BF-8: M20 Main Frame (White) | GM-6: Drive Roller, Axle & Bearings |
| UF-6: Right Side Coupling & Clamp Lever | GM-7: Drive Roller Holder |
| UF-7: Clamp Lever Guide | GM-9: Axle End Cap |
| UF-8: Left Side Coupling (for Q/R Lever) | GM-10: Mag Unit Fitting Bracket |
| UF-9: Coupling Lock Ring (Red) | GM-11: Rubber Shim |
| M5-2: Rubber Foot Cap (29mm) | GM-12: Mount Base |
| MF-3: Roller Pressure Adjust Knob Set | GM-13: Rubber Washer & Bolt Set |
| GM-2: Alloy Rotor | GM-16: Flywheel (1.5kg) |
| GM-3: Housing Cover | GM-24: Remote Shifter (White) |

How To Setup Your M20-V Trainer

Required Tools: 1 x 10mm Spanner
1 x M4 Hex Wrench

1. Replace your rear wheel quick release skewer to the supplied one.
Minoura guarantees the stability only when using the supplied skewer due to the coupling inner shape.



If your bike is not equipped with quick release skewer and it's a hub nut type, replace the left side coupling (UF-8) to the optional "Left Side Coupling for Hub Nut Axle".

Minoura doesn't guarantee the stability if you don't replace the left side coupling.



You don't need the supplied quick release skewer if your wheel is a hub nut type. It's not possible to convert your wheel from the hub nut type to the quick release skewer type unless replacing the hub.

2. Install the Roller Pressure Adjust Knob set (MF-3) to M20-V frame. (see Fig. A)
Insert the flat washer and acorn spring into the knob bolt first, then screw the knob set to the welded nut on the bracket.



Make sure the acorn shaped spring direction is as shown in Fig. A.

Failure will cause difficulty on rotating.



If you feel some difficulty of the vertical action of the Mag resistance unit, slightly loosen the pivot bolt which connects the Mag unit to the frame.

Do not over-loosen the pivot bolt. It may cause injury to your finger when the Mag unit suddenly drops down.

3. Fully open both legs and place M20-V on a flat and level floor. (see Fig. B)
At this moment, make sure all 4 feet are contacting the floor at once to sit on the floor stable.

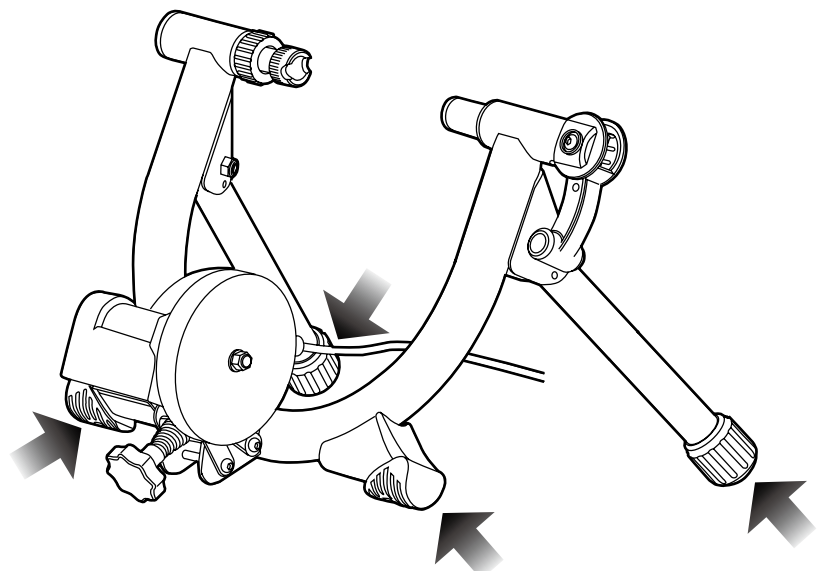
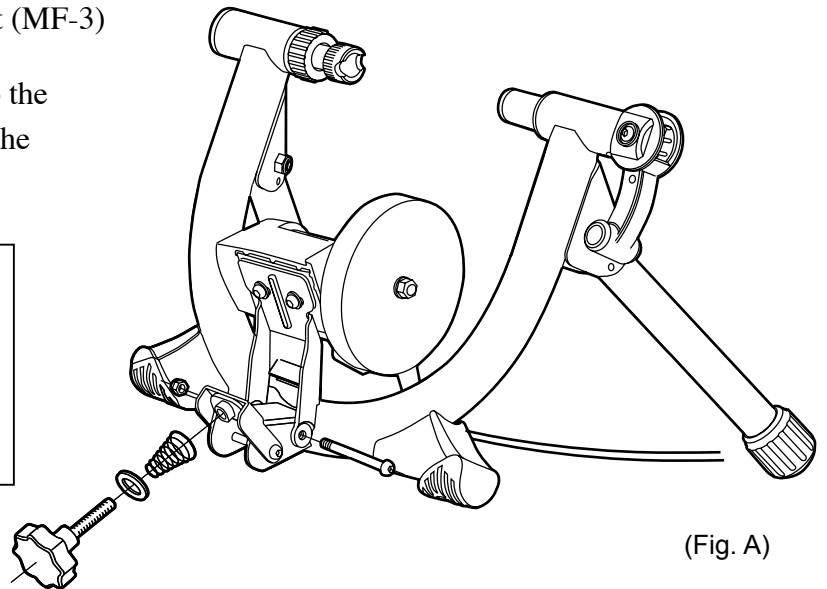

4. Place your rear wheel in between the couplings.

1) Loosen the lock ring (UF-9) to allow the left side coupling (UF-8) be free. (see Fig. C)

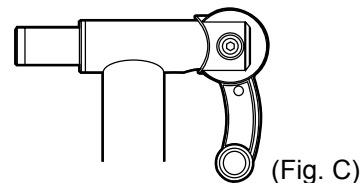
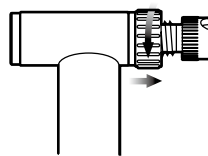

2) Pull up the quick hub clamp lever (UF-6) to retract the right side coupling. (see Fig. D)

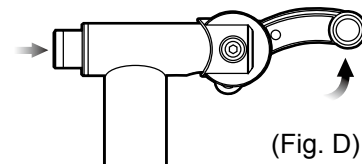
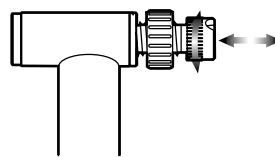

3) Insert the left side (quick lever side) skewer into the left side coupling first.

The quick lever shaft must be inserted into the cut-out on the coupling to hold the bike stable. Turn the coupling to adjust the cut-out position.

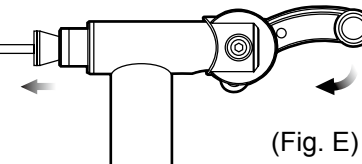
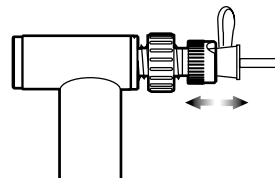

4) While keeping this position, slowly come down the bike to align the right side acorn nut to the right side coupling.

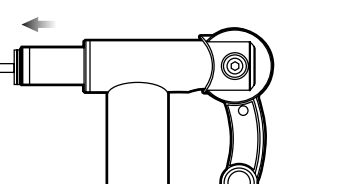
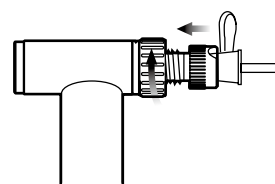

5) Push down the quick hub clamp lever to hold the rear wheel. (see Fig. E)

If you start feeling resistance when the lever comes at 4 o'clock position, it's correct.

If the clamping hub is too tight or too loose due to wrong position of the left side coupling, pull up the lever to release the bike, adjust the left side coupling position and try clamping the hub again.

6) Lastly, tighten the lock ring to fix the left side coupling position. (see Fig. F)



Both right and left side couplings are designed to suit the supplied quick release skewer. The left side coupling must fit perfectly in the skewer head to get correct stability. (see Fig. G)

Any skewer type which lever is located on the end of the axle (Fig. H) or the lever will not be bent over right angle (Fig. I) cannot be used on M20-V.

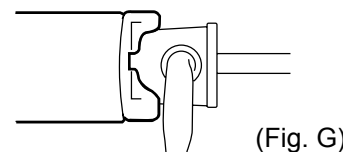

Precisely adjust the left side coupling position to keep the correct tightness of rear hub clamping. Too tight setting will cause damage to both M20-V and your bike frame. Too loose setting may cause the bike to come out of the trainer during use.

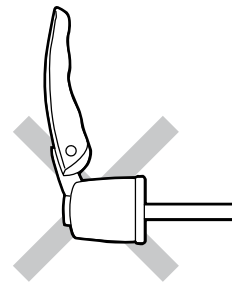
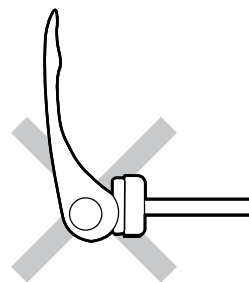

- 5.** Contact the Drive Roller to the rear tire by turning the Roller Pressure Adjust Knob clockwise. (see Fig. J)
The best position is that the roller compresses the tire in the depth of 3 - 4 mm. (see Fig. K)



Please note too much and too less roller pressure will bring premature tire wear. Keep correct roller pressure and maintain the air pressure in correct level before using M20-V.

TIPS If it's hard to tighten the knob bolt, lift up the Mag unit by hand then tighten the knob.

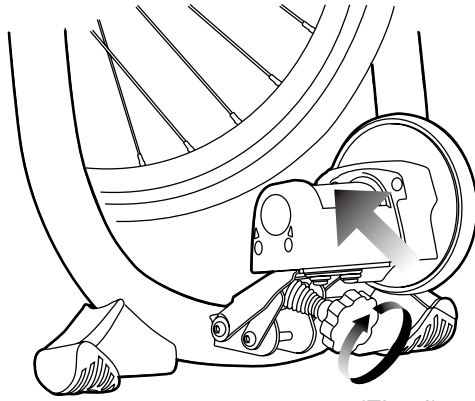

(Fig. J)

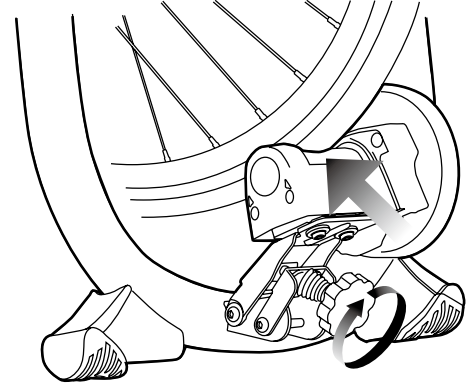

(Fig. K)

- 6.** The rear tire should sit in the almost center part of the Drive Roller without touching any other parts. (see Fig. L)

If the tire has touched the plastic parts (Fig. M) due to some reasons like the rear wheel is not trued correctly or you have installed a too fat tire, you must adjust the Mag unit position.

To do so, loosen the backside screws with M5 hex wrench, adjust the roller position, then tighten the screws again tightly. (see Fig. N)

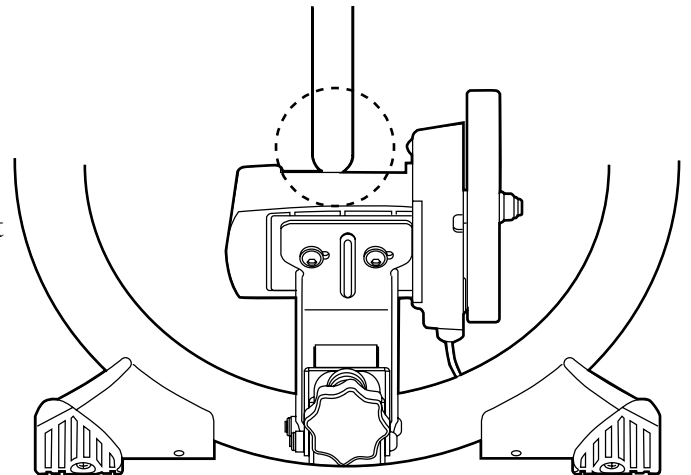

(Fig. L)

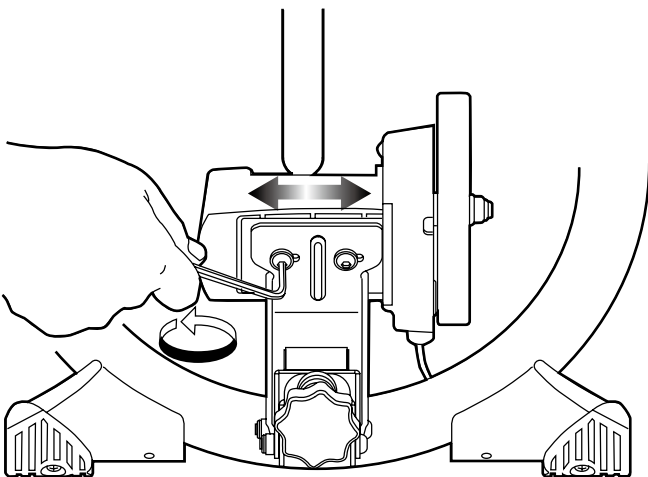

(Fig. M)

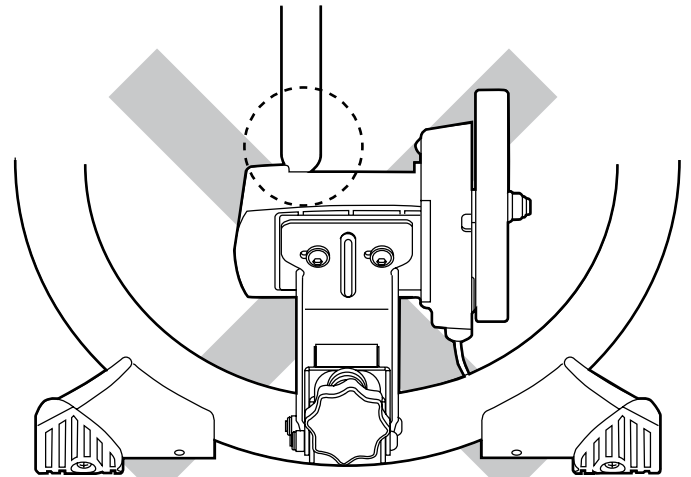

(Fig. N)



If the rear tire has touched any other parts than the Drive Roller, the part may be damaged and your tire will wear out quickly.



It is impossible to adjust the rear wheel position by adjusting the left side coupling position. It just works to adjust the coupling distance.

- 5.** To remove the bike from M20-V, loosen the knob first, then lift up the clamp lever. If you remove the bike without changing the roller position, the next installation may become difficult because the rear wheel has been pushed forward by the roller.

How To Adjust Resistance Level

M20-V features a convenient remote shifter lever. You can install it on the handlebar or stem, then you can control the resistance level without getting off the bike.

- 1.** Wind the band around the handlebar and hook the metal ring to the gutter on the remote shifter base. (see Fig. O-1)
- 2.** Flip up the lever to lock (see Fig. O-2). If it is loosened, adjust the band tighter as per instructed in the following section.
- 3.** The soft fabric band is pre-adjusted to fit normal 22mm diameter handlebar. If you need to mount onto an oversized or specially shaped handlebar or stem, adjust the band (see Fig. P). At this moment, we suggest you to slide the guide pin downward (see the column) to loosen the band for easier work.

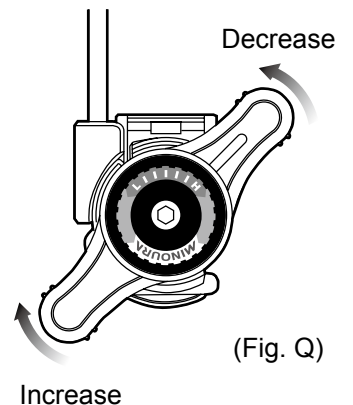
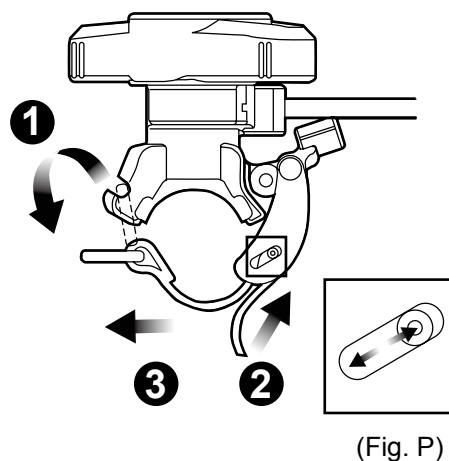
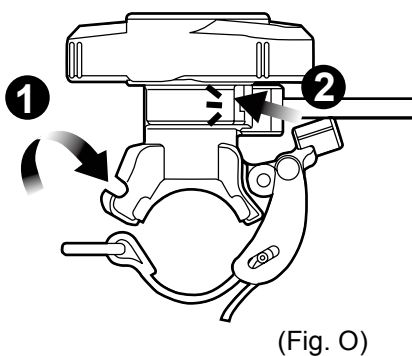

- 4.** To increase the resistance, twist the lever toward "H". To decrease the resistance, twist the lever toward "L". (see Fig. Q)
You can choose from 7 different levels to suit your desired workout level.

Why My Remote Shifter Doesn't Work Properly?

You may have a shifting problem that you cannot set at L or H position properly due to the lengthened inner cable. To fix this problem, follow the steps to adjust the initial cable tension.

- 1.** Set your remote shifter at "H" position and remove the shifter from your handlebar, then straighten the cable as much as possible.
- 2.** Pull out the plastic cover cap on foot of the remote cable. (see Fig. R & S)
- 3.** Hold the inside adjusting screw and push it toward the shifter, then adjust the locking nut to set the cable tension properly. (see Fig. T)
- 4.** Install the cover cap again.

