

RESOLUTION DIAGRAM

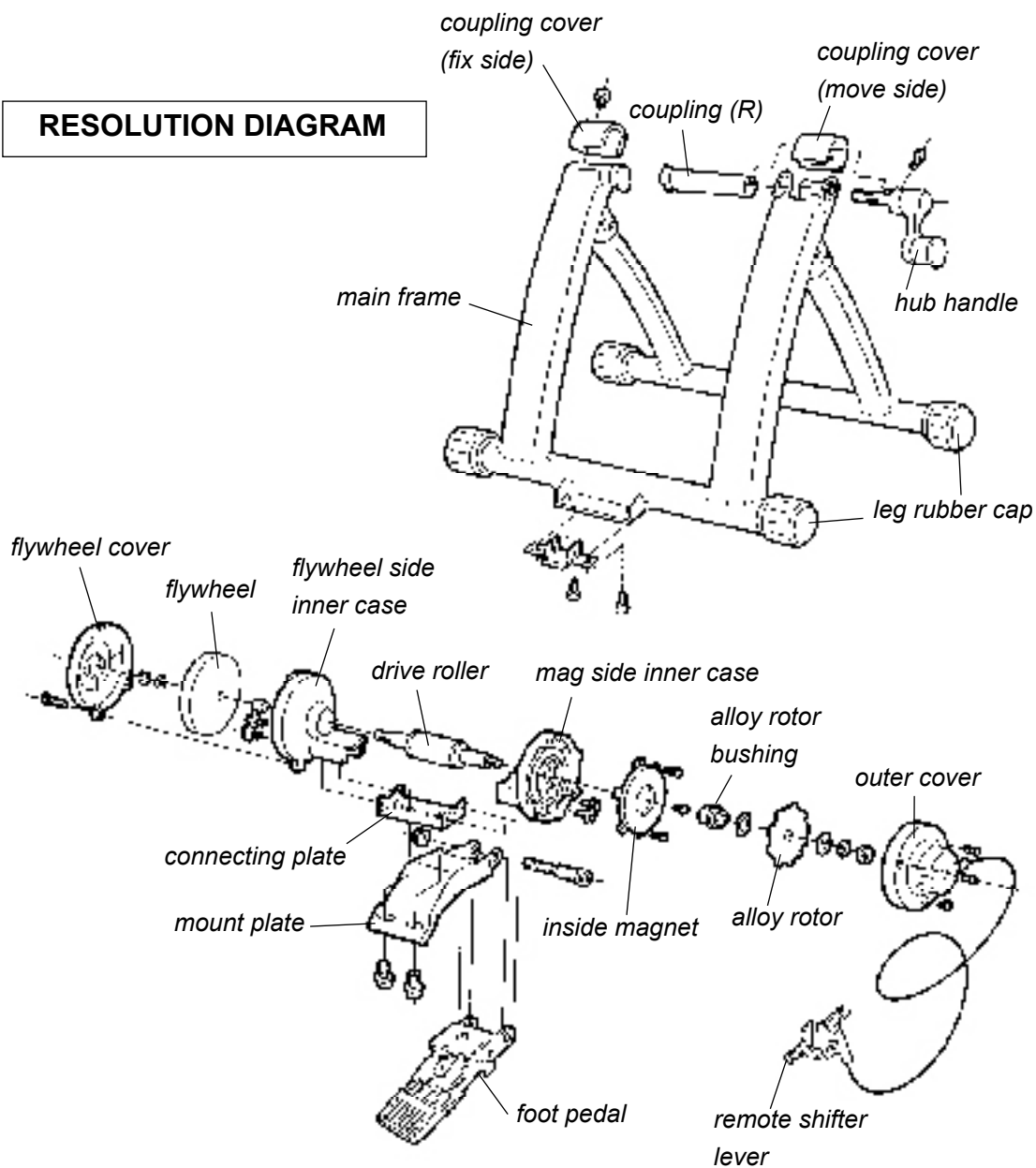

WARRANTY PARTS

- 400-7102-00 : Remote Mag resistance unit
- 400-7103-00 : Remote Outer Cover
- 400-7005-00 : Flywheel cover
- 400-4604-00 : Hub handle
- 400-1243-00 : Coupling (right side)
- 400-4509-00 : Foot pedal

- 400-7003-00 : Mag side inner case
- 400-7004-00 : Flywheel side inner case
- 400-7002-00 : Drive roller w/ bearing
- 400-4605-00 : Leg rubber cap
- 400-4607-00 : Coupling cover (move side)
- 400-4608-00 : Coupling cover (fix side)

IMPORTANT NOTES

- Read all instructions including the back page of the POP card board carefully before use.
- Some assembly required.
- Keep the manual handy at all times.
- Do NOT use trainer for any other purpose than instructed.
- The trainer is manufactured to precise standards. You may not disassemble or rebuild it.
- "Magturbo" is the trademarks of Minoura Co.,Ltd. and may not be copied.

WARNINGS

- ⚠ Use two-wheeled bicycles only. Tandems may be used if balanced correctly.
- ⚠ Replace your quick release skewer to the supplied one and install the supplied coupling protector cap onto the right side coupling when you use the trainer. Otherwise the stability will not be guaranteed.
- ⚠ Remove the coupling protector cap when you use your own quick release skewer.
- ⚠ Remove all oils and moisture from the drive roller and the tire before use.
- ⚠ Keep both hands on handlebars at all times and maintain a normal riding position.
- ⚠ Check the couplings supporting the rear hub for damage and cracks. Accidents may occur from cracked or damaged couplings.
- ⚠ When using the trainer, place it on a flat surface for safe training.
- ⚠ Do not over tighten the hub-clamp handles. Over-tightening may cause damage to the trainer or bicycle frame. The clamp handles should be a snug and secure fit. Do not force!
- ⚠ Before use, make sure all bolts and nuts are securely fastened.
- ⚠ Keep away from small children, and keep hands and feet away from spinning rollers and wheels at all times.
- ⚠ Open the legs fully to get maximum stability.

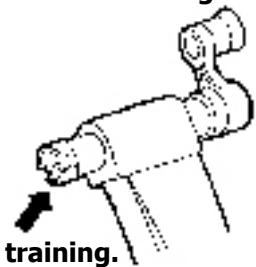

USING THE MAGTURBO UNIT

The Magturbo unit has 7 different levels of load force, replicating actual riding resistance. The load settings range from high (H) to low (L) and can be adjusted via the lever on the thumb shifter device. The rider may also adjust the load force by shifting up or down among his gears, depending on the level desired.

We recommend that you start with a medium to low load force and gradually work up, increasing force as muscled warm up.

Increasing Load Force

To increase the load force, turn the lever on your thumb shifter device toward the (H) symbol. (see Fig. A)

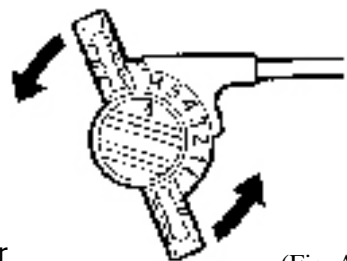

(Fig. A)

Decreasing Load Force

To decrease the load force, turn the lever on your thumb shifter device toward the (L) symbol. (see Fig. A)

Be sure the lowest selection is not zero load, there still be a small level of force.



You must not be riding the trainer when you are adjusting the white lever on the Mag unit for load force. Make sure all parts have stopped spinning. Do not try to adjust the lever with your feet while riding.

Trouble Shooting Your Remote Shifter Unit

If you cannot shift to either the lowest (L) or the highest (H) position, it is possible that the inner wire of the remote shifter cable is too long and the wire tension is loose. If so, please adjust the tension with the following steps;

1.

Set the remote shifter lever at "H" position. Remove the remote shifter device from the handlebar and straighten the cable.

2.

Remove the plastic cap located on the bottom of the cable. (see Fig. B)

3.

Hold the adjusting screw with your right hand and push it towards the direction of the outer cable, then adjust the nut with your left hand to make the wire tension properly.

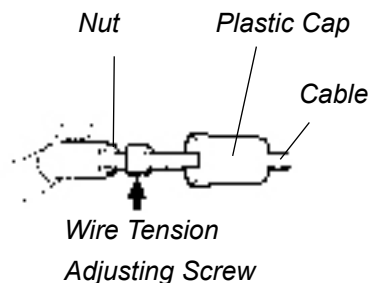

(Fig. B)

FOR MORE INFORMATION

MINOURA JAPAN HEAD OFFICE

1197-1 Godo, Anpachi, Gifu 503-2305 JAPAN
Phone +81- (0)584-27-3131 / Fax +81- (0)584-27-7505
E-mail: minoura@minoura.jp
[http:// www.minoura.jp](http://www.minoura.jp)

MINOURA NORTH AMERICAN CENTER FOR RESEARCH, DEVELOPMENT & MARKETING

1996 East Avenue, Hayward, CA 94541-5454 U.S.A.
Phone 510-538-8599 / Fax 510-538-5899
E-mail : MinouraUSA@ATTglobal.net

Made & Quality Controlled in Japan

Copyright © 2002 Minoura Japan, All Rights Reserved.