

MINOURN GravityStand 2 instructions manual

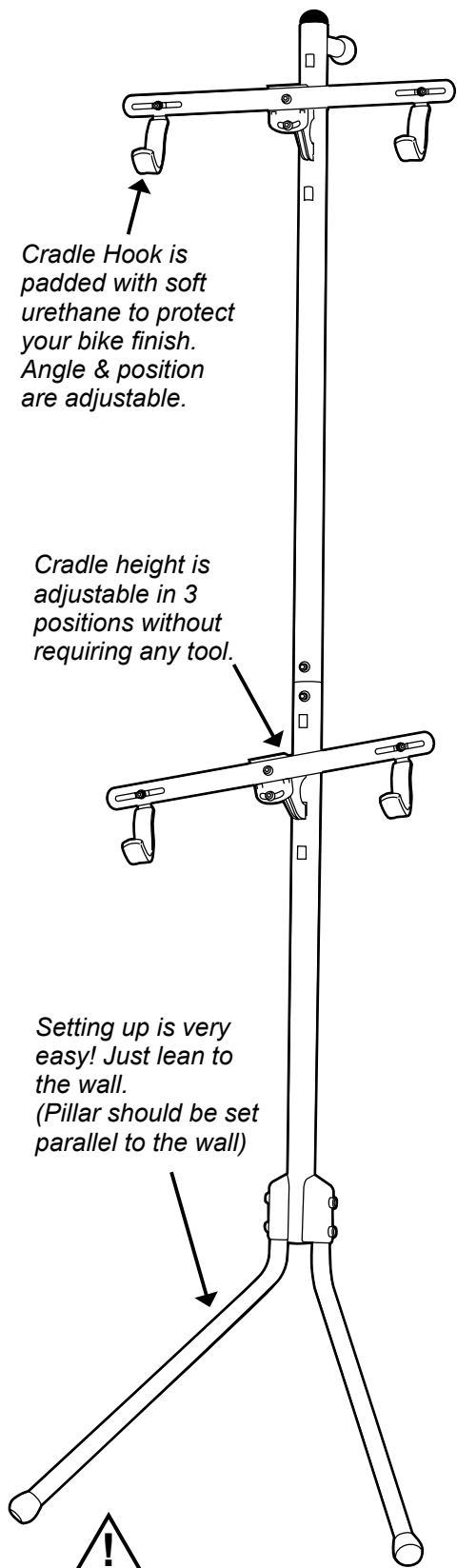

GravityStand is designed to keep enough stability. But we highly recommend you to fix the stand to the wall with the supplied strap to prevent any accident.

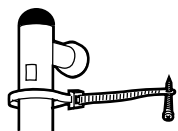

M3.5x15 or 25 Screw

1 Insert Plastic Bracket into each Leg.

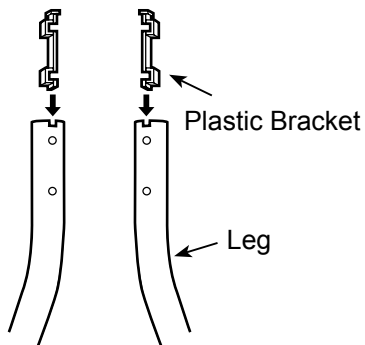

2 Insert Metal Plate into Lower Pillar, put Plastic Cover onto each Leg, then put through Guide Pin into either hole for temporarily assembling.

Be sure the square holes on Lower Pillar must face to front side.

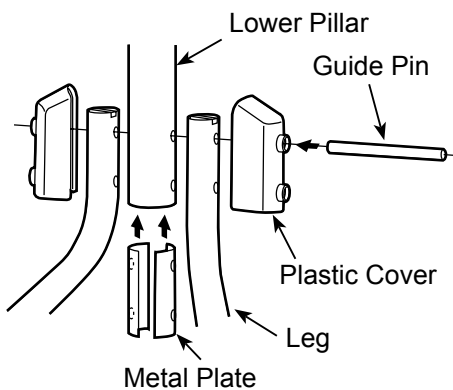

3 Screw M6x40 Bolt into the hole without Guide Pin. (You don't need to tighten the bolts so much now.)

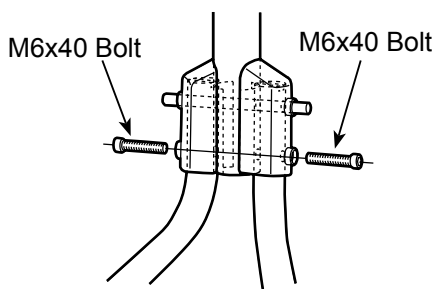

4 Remove Guide Pin.

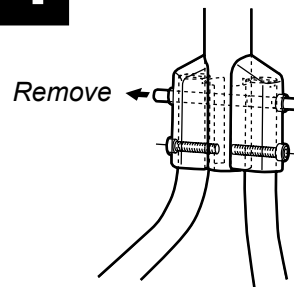

5 Screw M6x40 Bolt to another hole.

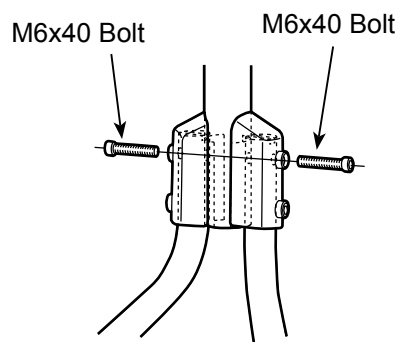

6 Tighten all M6x40 Bolts firmly.

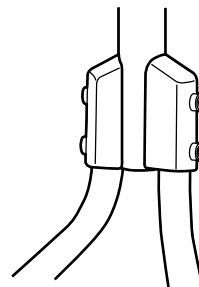

7 Install Metal Plate to the top holes on Lower Pillar with M6x12 Bolt.

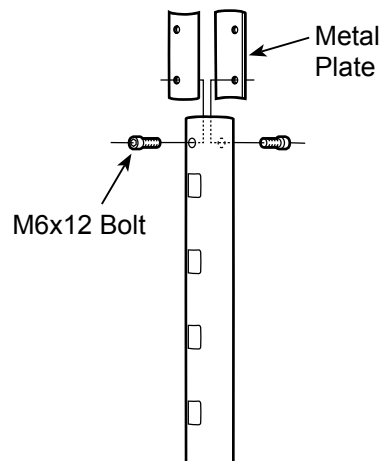

- 8** Joint Upper Pillar to the installed Metal Plates. Make sure the square holes on Upper Pillar align the same. Tighten M6x12 Bolt firmly.

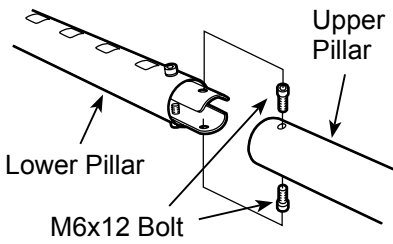

- 9** Install Cradle Base to your favorite hole. Hook both ends to the square holes then slide down to fix.

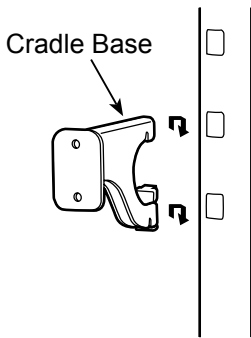

- 10** Push Lock Lever toward the pillar to lock Cradle Base position.

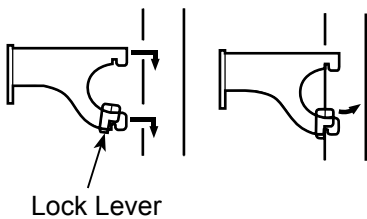

To change Cradle Base position, pull back Lock Lever then pull out the cradle.



Use screwdriver to release Lock Lever. Do NOT do with your finger, otherwise your nail may be damaged.

- 11** Assemble Bike Cradle.

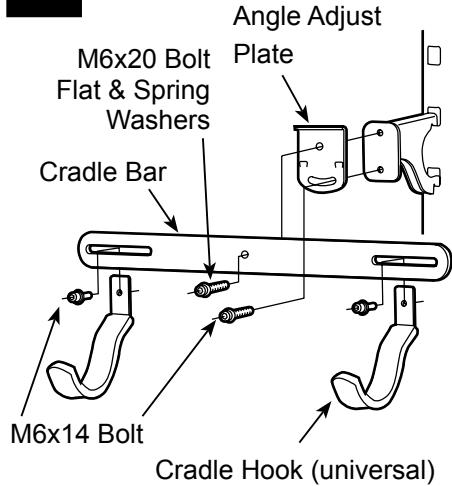

Set Angle Adjust Plate as the long hole is set downward. Cradle Hook must be installed from back of Cradle Bar to prevent scratching problem to your bike frame.

- 12** Set and lean GravityStand to the wall. The pillar must be set parallel to the wall to keep best stability.

Put the top-tube of your bike on Cradle Hooks gently.



Do NOT apply any paper or thin plate under Legs to prevent slippage accident.

- 13** Bike cradle is angle adjustable to fit to your bike's top-tube angle. Loosen the lower bolt (long hole side) to adjust. After that tighten the bolt firmly.

The bike should be as horizontal as possible.

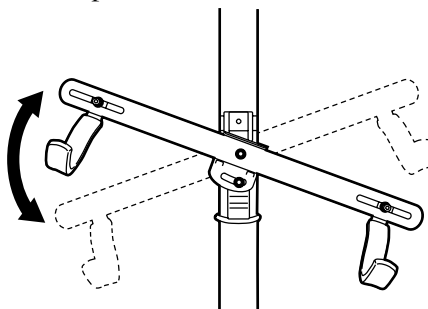

Each position and angle of Cradle Hook is also adjustable.

IMPORTANT NOTES

- Gravity Stand is only for normal 2-wheel bikes. Do not use for any other purposes.
- Gravity Stand will not supported nor fixed. Be careful not to hit the stand when you passing nearby.
- Gravity Stand is designed to keep enough stability even having heavy shocks. But we highly recommend you to fix the stand to the wall with the supplied strap.
- Remove any sand and dust from the area Leg touches to prevent slippage problem.
- Check every bolt regularly and tighten firmly with proper tool if you find any loose.
- Minoura offers 1-year limited warranty from the date of your purchase. Any problem caused by manufacturer's defect and wrong workmanship will be covered by this program. But any trouble caused by user's misuse, unapproved modification, natural calamity and every problem happened during shipment will NOT be covered by Minoura. For more detail, please refer the attached "Warranty Program Instruction" card.

FOR MORE INFORMATION

If you have any question, contact the shop where you purchased or your local distributor first.

MINOURA JAPAN

1197-1 Godo, Anpachi, Gifu 503-2305
 Phone +81-584-27-3131
 Fax +81-584-27-7505
 Mail minoura@minoura.jp
 Web www.minoura.jp

MINOURA NORTH AMERICA

Mail support@minourausa.com