

Thank you for purchasing the Minoura FCG-310 wheel dishing gauge. This is the tool to check if the wheel is exactly symmetrical for better ride. You can use FCG-310 on most size of wheels between 18" and 27"/700c. Please read this instructions manual carefully before use and understand the mechanism of bicycle wheel.

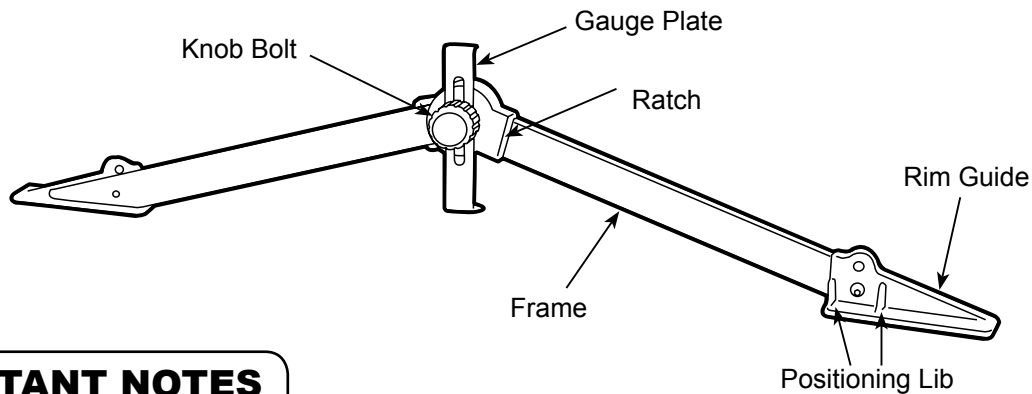

IMPORTANT NOTES



FCG-310 is the measuring gauge for bicycle wheel only. Do not use it for any other purpose than instructed.



FCG-310 is a precision tool so please handle it with care. Do not hit or bend the frame and gauge plate.



Be careful not to pinch your fingers when opening or closing the FCG-310.

How To Use FCG-310

- 1.** To open the FCG-310, loosen the Knob Bolt then open the Frame with both hands.
- 2.** Look for the grooves on the inside of the Ratches that fix the angle when the Frame is opened. Extend until the grooves meet and lock into place by pushing them each other.
- 3.** Turn the Gauge Plate counter-clockwise to locate the hole at the down end side. Put the Gauge Plate on the flat groove on the outside of the Ratch.
- 4.** Tighten the Knob Bolt, but you don't need to tighten it so firmly at this moment.



If the Gauge Plate doesn't fit to the flat groove on the Ratch correctly, you won't be able to measure properly. And also the Gauge Plate will have to be bent. Please be sure that the Gauge Plate cannot be replaced.

- 5.** Attach the FCG-310 to the wheel as shown in Fig. A. While keeping both Rim Guides touching the rim, loosen the Knob Bolt to adjust the Gauge Plate position, then tighten the Knob Bolt firmly.

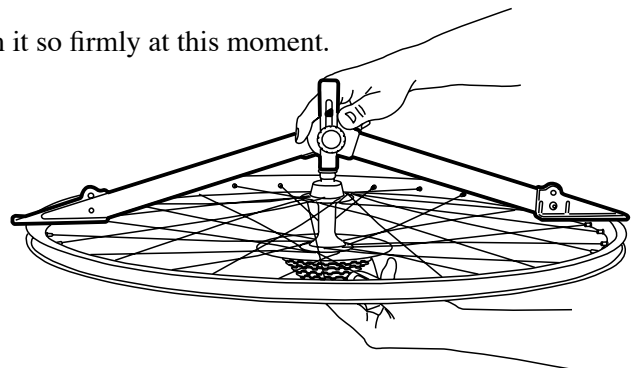

(Fig. A)



At this moment, make sure the following points;

- **Both Rim Guides touch the rim.**
- **The wheel axle is running through the hole on the Gauge Plate, and the Gauge Plate touches the hub.**

- 6.** Flip over the wheel and attach the FCG-310 onto the opposite side of the wheel. Do not change the Gauge Plate position yet.

At this time, if all three points (both Rim Guides and the tip of the Gauge Plate) touch each appropriate position at once on both side of the wheel (see Fig. B), your wheel is properly assembled and adjusted.

But if either one of the Rim Guides or the Gauge Plate doesn't touch the appropriate position (see Fig. C), your wheel needs to be adjusted further.

If the Rim Guide doesn't touch the rim, the wheel has been moved toward opposite side.

If the Gauge Plate doesn't touch the hub even though both Rim Guides touch the rim, your wheel has been moved backward.

Set the wheel on the wheel truing stand to adjust. To know how to adjust the wheel, refer the instructions manual of the truing stand.



It is crucial to measure the wheel at several different points to get proper result.

Useful Additional Features

FCG-310 can be used on most wheels sized between 24" and 27"/700c in the standard position.

In addition, you can use it for the smaller wheel (18" or larger) and the wide hub wheel which is used on some DH, FR and city commuting bikes by changing the the Rim Guide position. (see Fig. D & E)

<To Measure Smaller Wheel>
Make both Rim Guides inward

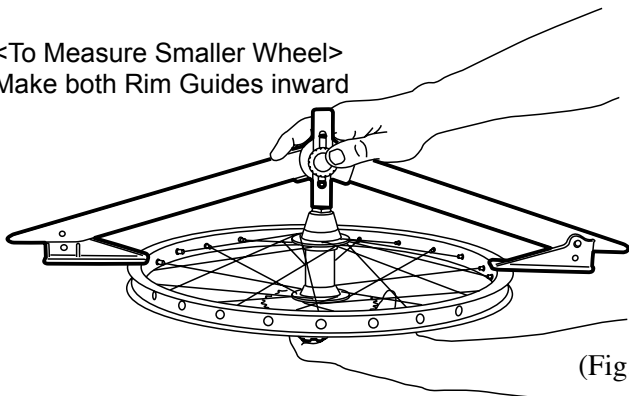

(Fig. D)

<To Measure Wide Hub>
Step down both Rim Guides

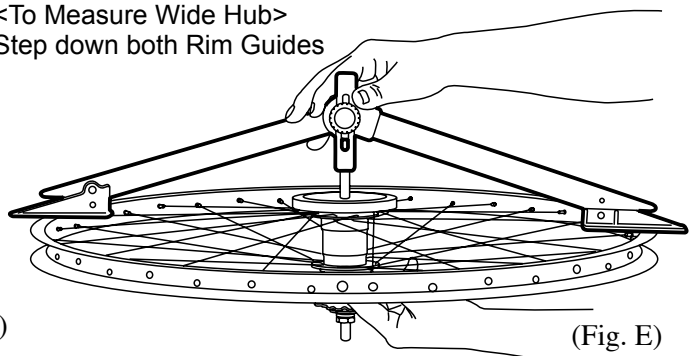

(Fig. E)

How To Fold Down FCG-310

To fold down the FCG-310, 1) loosen the Knob Bolt fully, 2) separate the Ratches as if pulling outward on each other, 3) rotate the Gauge Plate as the hole faces outward, then 4) fold the Frame.



Do not tighten the Knob Bolt while the hole of the Gauge Plate is facing inward, otherwise the Gauge Plate will be bent. Please be sure the Gauge Plate cannot be replaced.

The hole must be outward

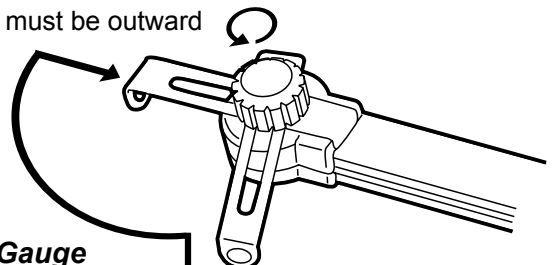

(Fig. F)

MINOURA JAPAN (for ALL customers)
1197-1 Godo, Anpachi, Gifu 503-2305 Japan
Phone +81-584-27-3131 / Fax +81-584-27-7505
Email minoura@minoura.jp

MINOURA NORTH AMERICA (for U.S. residents only)
1996 East Ave, Hayward, CA 94541-5454 U.S.A.
Phone 1-510-538-8599 / Fax 1-510-538-5899
Email support@minourausa.com